



X10 & HX10

Swing-Away Grain Auger Operator's Manual

This manual applies to:

Westfield X10, AGI X10, Hutchinson HX10, Mayrath HX10:
63', 73', 83'

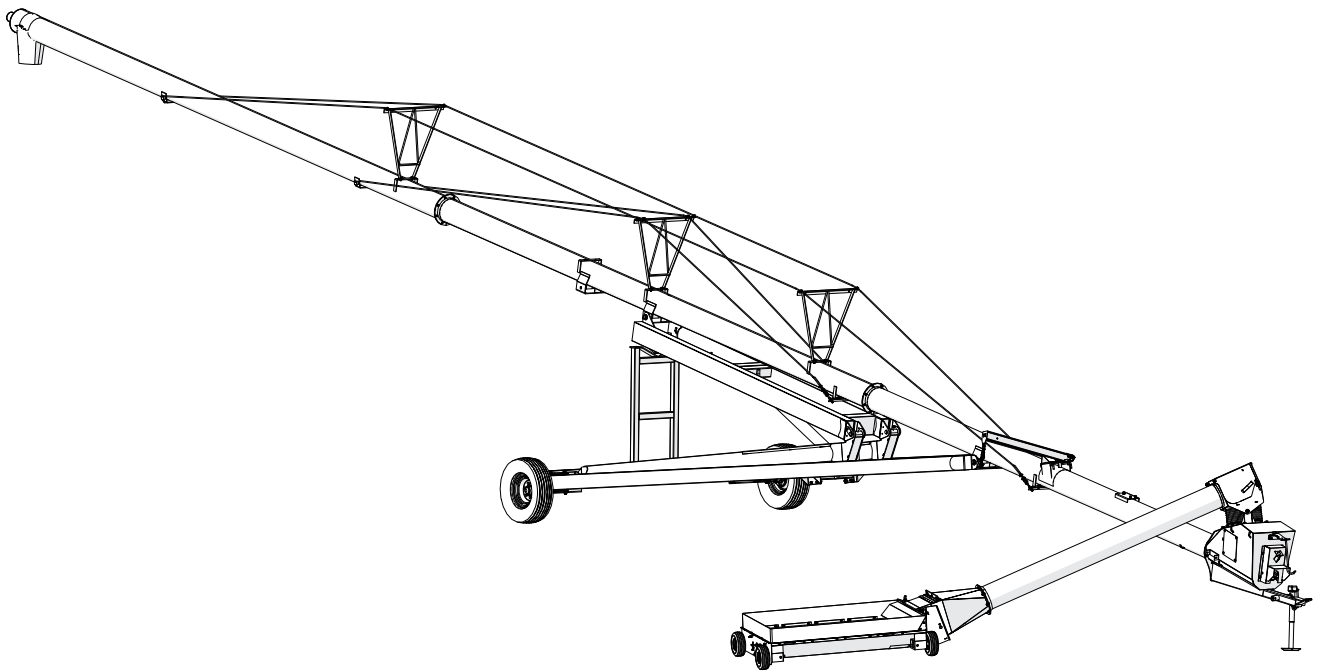

Read this manual before using product. Failure to follow instructions and safety precautions can result in serious injury, death, or property damage. Keep manual for future reference.

Part Number: 31073 R1

Revised: October 2020

Original Instructions

CONTENTS

- 1. Introduction 5**
 - 1.1 Serial Number Location 5
 - 1.2 Intended Use 6
 - 1.2.1 Misuse 6

- 2. Safety..... 7**
 - 2.1 Safety Alert Symbol and Signal Words..... 7
 - 2.2 Follow Safety Instructions 7
 - 2.3 Rotating Flighting Safety 8
 - 2.4 Overhead Power Lines 8
 - 2.5 Upending 8
 - 2.6 Rotating Parts Safety..... 8
 - 2.7 Work Area Safety 9
 - 2.8 Guards Safety 10
 - 2.9 Raising and Lowering the Auger 10
 - 2.10 Hand Winch Safety..... 10
 - 2.11 Hydraulic Winch Safety 11
 - 2.12 Positioning the Auger..... 11
 - 2.13 Towing the Auger 11
 - 2.14 Drives and Lockout Safety..... 12
 - 2.14.1 PTO Driveline Safety..... 12
 - 2.14.2 Hydraulic Power Safety 13
 - 2.15 Tire Safety..... 14
 - 2.16 Personal Protective Equipment..... 14
 - 2.17 Safety Equipment 15
 - 2.18 Safety Decals 15
 - 2.18.1 Decal Installation/Replacement..... 16
 - 2.18.2 Safety Decal Locations and Details 16

- 3. Features..... 26**

- 4. Transport..... 29**
 - 4.1 Transport Safety 29
 - 4.2 Transport Preparation..... 30
 - 4.3 Connecting the Auger to the Towing Vehicle 30

- 5. Placement 32**
 - 5.1 Placement Safety..... 32
 - 5.2 Positioning the Auger..... 32
 - 5.2.1 Raising and Lowering 34
 - 5.3 Extendable Axle Positioning..... 35
 - 5.4 Auger-to-Tractor Hookup 36
 - 5.5 Raising and Lowering the Intake Hopper..... 38
 - 5.5.1 Swing-Away Hydraulic Winch Operation 39
 - 5.6 Grain Hopper Positioning..... 40
 - 5.6.1 Electric Power Swing Operation 40
 - 5.6.2 Hydraulic Power Swing Operation 42
 - 5.7 Positioning the Tractor for Right Angle Drive Operation 43

- 6. Operation 45**

| | |
|--|-----------|
| 6.1 Operation Safety | 45 |
| 6.2 Start-up and Break-in | 45 |
| 6.3 Operation - PTO Drive | 46 |
| 6.3.1 PTO Operation — Forward and Reverse Modes | 46 |
| 6.4 Safety Discharge Door | 47 |
| 6.5 Emergency Shutdown | 48 |
| 6.6 Restarting with a Full Tube | 48 |
| 6.7 Bin Level Indicators | 48 |
| 6.8 Use of Grain Spreaders | 48 |
| 6.9 Shutdown | 48 |
| 6.10 Operating the Auger with Fertilizer | 49 |
| 6.11 Storage..... | 49 |
| 7. Maintenance | 51 |
| 7.1 Maintenance Safety | 51 |
| 7.2 Maintenance Schedule | 51 |
| 7.3 Visually Inspect the Equipment..... | 52 |
| 7.4 Lubricate the Equipment..... | 53 |
| 7.4.1 Grease Points | 53 |
| 7.5 Inspect Hydraulic Hoses and Fittings | 55 |
| 7.6 Inspect and Service the Hand Winch and Lift Cable..... | 55 |
| 7.7 Inspect and Service the Hydraulic Winch and Lift Cable | 56 |
| 7.8 Service the Pulleys..... | 56 |
| 7.9 Service the Swing Tube Coupler Chain | 57 |
| 7.10 Service the Boot and Hopper Chain Drive | 57 |
| 7.11 Check the Gearbox Oil..... | 58 |
| 7.11.1 Gearbox Access | 59 |
| 7.12 Change the Gearbox Oil | 59 |
| 7.13 Service the Power Swing Drive Chain | 59 |
| 7.14 Clean and Wash the Equipment | 59 |
| 7.15 Removable Hopper Mesh Guard | 60 |
| 7.16 Repack the Wheel Bearings with Grease..... | 60 |
| 7.17 Check/Adjust the Truss Cables..... | 61 |
| 8. Troubleshooting..... | 63 |
| 9. Specifications | 65 |
| 10. Appendix | 66 |
| 10.1 Power Swing Remote Transmitter Instructions | 66 |
| 10.2 Programming Receivers | 67 |
| 10.3 How to Charge the Lift System | 68 |
| 10.4 Open/Closed-Center Valve Conversion..... | 69 |
| 11. AGI Limited Warranty..... | 70 |

1. Introduction

Thank you for your purchase. Follow the instructions in this manual for safe use of this auger. Following proper operation and maintenance will help to keep the auger running in optimal condition.

Keep this manual handy for frequent reference and to review with new personnel. A sign-off form is provided on the inside front cover for your convenience. If any information in this manual is not understood or if you need additional information, please contact AGI or your representative for assistance.

This manual should be regarded as part of the equipment.

1.1. Serial Number Location

The serial number location for your auger is shown in the figure below. Have the serial number ready when ordering parts or requesting service or other information. Record information in the table below for easy reference.

| | |
|----------------------|--|
| Model Number | |
| Serial Number | |
| Date Received | |

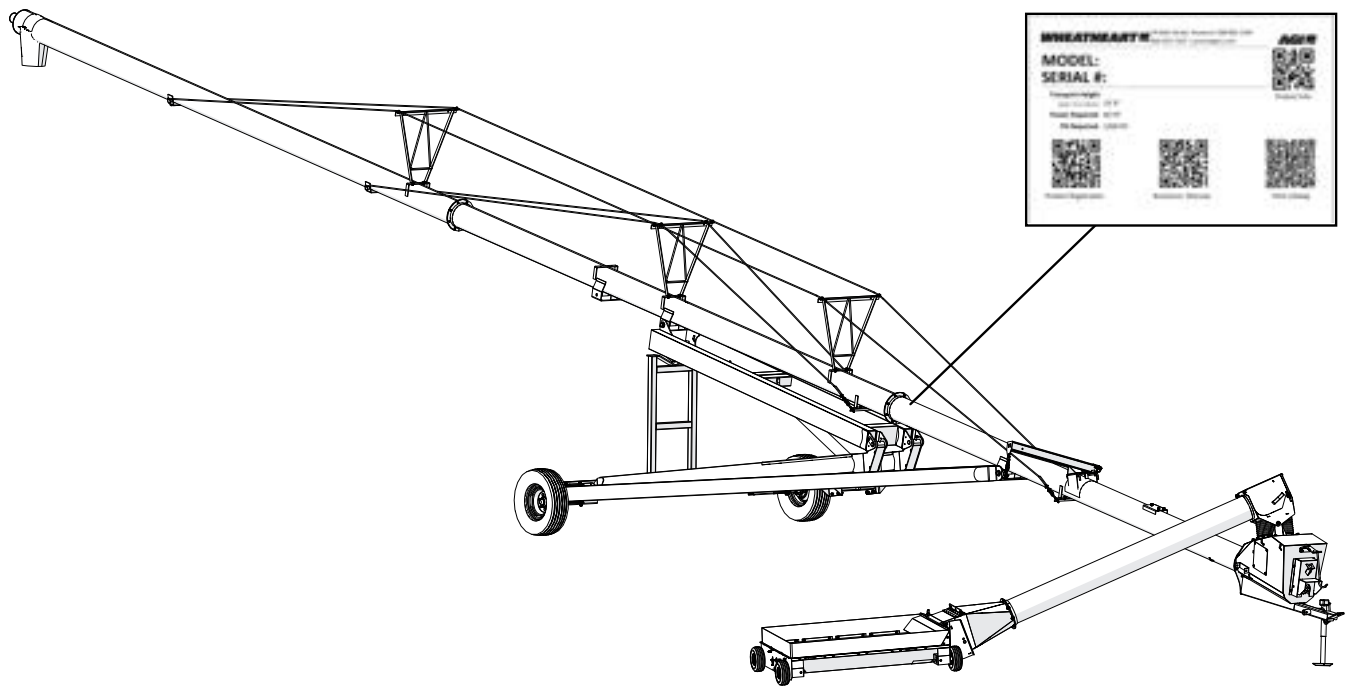

1.2. Intended Use

The auger is intended for use as listed below and described throughout this manual. Use in any other way is considered contrary to the intended use and is not covered by the warranty.

Intended use for the auger:

- Handling grain, pulse crops, treated seeds, or other similar materials.

1.2.1 Misuse

Do not install/use the auger for/with:

- transferring material other than dry, free-flowing food-grains.
- lifting or using as a hoist or crane.



2. Safety

2.1. Safety Alert Symbol and Signal Words

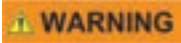

This safety alert symbol indicates important safety messages in this manual. When you see this symbol, be alert to the possibility of injury or death, carefully read the message that follows, and inform others.

Signal Words: Note the use of the signal words **DANGER**, **WARNING**, **CAUTION**, and **NOTICE** with the safety messages. The appropriate signal word for each message has been selected using the definitions below as a guideline.

| | |
|--|---|
|  DANGER | Indicates an imminently hazardous situation that, if not avoided, will result in serious injury or death. |
|  WARNING | Indicates a hazardous situation that, if not avoided, could result in serious injury or death. |
|  CAUTION | Indicates a hazardous situation that, if not avoided, may result in minor or moderate injury. |
|  NOTICE | Indicates a potentially hazardous situation that, if not avoided, may result in property damage. |

2.2. Follow Safety Instructions

Read and understand all safety instructions, safety decals, and manuals and follow them when operating or maintaining the equipment.

- Owners must give instructions and review the information initially and annually with all personnel before allowing them in the work area. Untrained users/operators expose themselves and bystanders to possible serious injury or death.
- Use for intended purposes only.
- Do not modify the auger in any way without written permission from the manufacturer and is not covered by the warranty.
- Follow a health and safety program for your worksite. Contact your local occupational health and safety organization for information.
- Follow applicable local codes and regulations.



2.3. Rotating Flighting Safety

DANGER

- KEEP AWAY from rotating flighting.
- DO NOT remove or modify flighting guards, doors, or covers. Keep in good working order. Have replaced if damaged.
- DO NOT operate the auger without all guards, doors, and covers in place.
- NEVER touch the flighting. Use a stick or other tool to remove an obstruction or clean out.
- Shut off and lock out power to adjust, service, or clean.



2.4. Overhead Power Lines

DANGER

- When operating or moving, keep auger away from overhead power lines and devices.
- The auger is not insulated.
- Electrocutation can occur without direct contact.



2.5. Upending

WARNING

- Anchor intake end and/or support discharge end to prevent upending.
- Intake end must always have downward weight. Do not release until attached to tow bar or resting on ground.
- Do not raise intake end above tow bar height.
- Empty the auger and fully lower before moving.

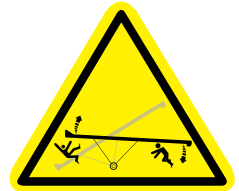

2.6. Rotating Parts Safety

WARNING

- Keep body, hair, and clothing away from rotating pulleys, belts, chains, and sprockets.
- Do not operate with any guard removed or modified. Keep guards in good working order.
- Shut off and lock out power source before inspecting or servicing machine.



2.7. Work Area Safety

- Have another trained person nearby who can shut down the auger in case of accident.
- The work area should be kept clear of bystanders, including children.
- Keep the work area clean and free of debris.

Figure 1. Auger Work Area

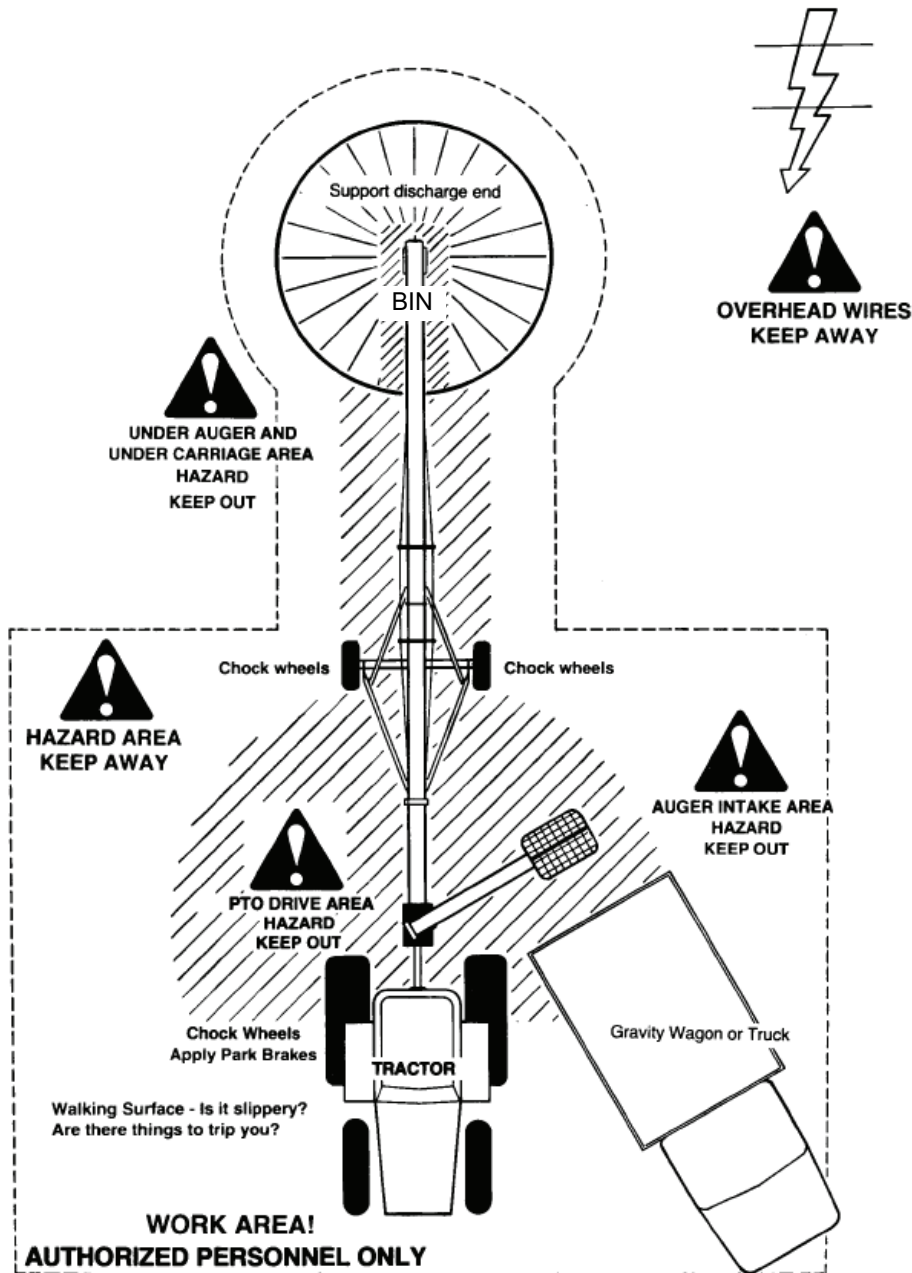

2.8. Guards Safety

- ⚠ WARNING**
- Keep guards in place. Do not operate with guard removed.
 - Do not walk on, step on, or damage guards.
 - Lock out power before removing a guard.
 - Ensure all guards are replaced after performing maintenance.

2.9. Raising and Lowering the Auger

- ⚠ WARNING**
- Before raising/lowering/moving/adjusting the auger, make sure the area around the auger is clear of obstructions and/or untrained personnel. Never allow anyone to stand on or beneath the auger when it is being placed.
 - Lower the auger to its lowest position when not in use.
 - Empty the auger before raising or lowering.
 - Do not get on or beneath the auger when raising or lowering.
 - Raise and lower auger on reasonably level ground only.
 - Never attempt to increase height of the auger by positioning wheels on lumber, blocks, or by any other means. To do so will result in damage to auger and/or serious injury.
 - Do not raise the auger in high winds.

2.10. Hand Winch Safety

- ⚠ WARNING** **When Equipped:**
- Inspect lift cable before using. Replace if frayed or damaged. Make sure lift cable is seated properly in cable sheaves and cable clamps are secure.
 - Tighten brake lock by turning winch handle clockwise at least two clicks after lowering the auger.
 - Lower the auger fully before towing, then rotate winch handle until cable has light tension.
 - Do not lubricate winch brake discs.

2.11. Hydraulic Winch Safety

WARNING When Equipped:

- Keep away from rotating cable drum and winch cable. Do not touch or grab cable while winch is being operated or use hands to guide the cable.
- Inspect cable and cable clamps before using hydraulic winch. Replace cable if frayed or damaged. Tighten cable clamps if necessary.
- Check the cable anchor on the winch drum is tight.
- Confirm hydraulic hoses are in good condition.
- Do not continue to supply power to hydraulic winch after the auger has reached full up position.
- Do not disconnect hydraulic quick couplers when lines are pressurized.
- Make sure lift cable is seated in cable pulley.
- Always keep a minimum of 3 cable wraps on the cable drum.

2.12. Positioning the Auger

- ### **WARNING**
- Transport and place equipment on reasonably level ground when raising, lowering, positioning, or operating.
 - Move the auger into position slowly. Do not unhitch and attempt to move by hand.
 - Chock wheels and anchor intake end after placement.

2.13. Towing the Auger

The auger is not intended for transport on public roads. If it requires transport on a public roadway, the following steps should be taken:

- ### **WARNING**
- Check with local authorities regarding transport on public roads. Obey all applicable laws and regulations.
 - Always travel at a safe speed, never exceeding 20 mph (32 km/h).
 - Reduce speed on rough surfaces.
 - Do not transport on slopes greater than 20°.
 - Use caution when turning corners or meeting traffic.
 - Make sure the SMV (slow moving vehicle) emblem and all the lights and reflectors that are required by local authorities are in place, are clean, and can be seen by all over-taking and oncoming traffic.
 - Always use hazard-warning flashers on tractor/towing vehicle when transporting unless prohibited by law.
 - Do not allow riders on the auger or towing vehicle during transport.
 - Attach to towing vehicle with an appropriate pin and retainer. Always attach safety chains.
 - Place the auger in the transport position before moving on roads.

2.14. Drives and Lockout Safety

Inspect the power source(s) before using and know how to shut down in an emergency. Whenever you service or adjust your equipment, make sure you shut down the power source and follow lockout and tagout procedures to prevent inadvertent start-up and hazardous energy release. Know the procedure(s) that applies to your equipment from the following power source(s). Ensure that only 1 key exists for each assigned lock, and that you are the only one that holds that key. Ensure that all personnel are clear before turning on power to equipment.



2.14.1 PTO Driveline Safety

WARNING Drive

- Keep body, hair, and clothing away from rotating PTO driveline.
- Make certain the driveline shields telescope and rotate freely on driveline before attaching.
- Make certain the driveline is securely attached at both ends.
- Do not operate auger unless all driveline, tractor, and equipment shields are in place and in good working order.
- Do not exceed the specified operating speed.
- Keep universal joint angles small and equal. Do not exceed maximum recommended length for PTO driveline.
- Engage tractor park brake and/or chock wheels.



Lockout

- Position all controls in neutral, shut off tractor's engine, and remove key from tractor.
- If removing key is impossible, remove PTO driveline from tractor.

2.14.2 Hydraulic Power Safety

WARNING Power Source

- Refer to the rules and regulations applicable to the power source operating your hydraulic drive.
- Do not connect or disconnect hydraulic lines while system is under pressure.
- Keep all hydraulic lines away from moving parts and pinch points.
- Escaping hydraulic fluid under pressure will cause serious injury if it penetrates the skin surface (serious infection or toxic reaction can develop). See a doctor immediately if injured.
- Use metal or wood as a backstop when searching for hydraulic leaks and wear proper hand and eye protection.
- Check all hydraulic components are tight and in good condition. Replace any worn, cut, abraded, flattened, or crimped hoses.
- Clean the connections before connecting to equipment.
- Do not attempt any makeshift repairs to the hydraulic fittings or hoses with tape, clamps, or adhesive. The hydraulic system operates under extremely high pressure; such repairs will fail suddenly and create a hazardous and unsafe condition.

Lockout

- Always place all hydraulic controls in neutral and relieve system pressure before disconnecting or working on hydraulic system.



2.15. Tire Safety

WARNING Failure to follow proper procedures when mounting a tire on a wheel or rim can produce an explosion that may result in serious injury or death.



- DO NOT attempt to mount a tire unless you have the proper equipment and experience to do the job.
- Have a qualified tire dealer or repair service perform required tire maintenance.
- When replacing worn tires, make sure they meet the original tire specifications. Never undersize the replacement tire.
- DO NOT weld to the tire rim with the tire mounted on the rim. This action may cause an explosion which could result in serious injury or death.
- Inflate tires to the manufacturer's recommended pressure.
- Tires should not be operated at speeds higher than their rated speed.
- Keep wheel lug nuts tightened to manufacturer's recommendations.
- Never reinflate a tire that has been run flat or seriously under-inflated without removing the tire from the wheel. Have the tire and wheel closely inspected for damage before remounting.

2.16. Personal Protective Equipment

The following Personal Protective Equipment (PPE) should be worn when operating or maintaining the equipment.

Safety Glasses

- Wear safety glasses at all times to protect eyes from debris.

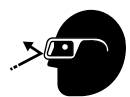

Coveralls

- Wear coveralls to protect skin.



Hard Hat

- Wear a hard hat to help protect your head.



Steel-Toe Boots

- Wear steel-toe boots to protect feet from falling debris.

**Work Gloves**

- Wear work gloves to protect your hands from sharp and rough edges.

**Dust Mask**

- Wear a dust mask to prevent breathing potentially harmful dust.

**Hearing Protection**

- Wear ear protection to prevent hearing damage.



2.17. Safety Equipment

The following safety equipment should be kept on site.

Fire Extinguisher

- Provide a fire extinguisher for use in case of an accident. Store in a highly visible and accessible place.

**First-Aid Kit**

- Have a properly-stocked first-aid kit available for use should the need arise, and know how to use it.



2.18. Safety Decals

- Keep safety decals clean and legible at all times.
- Replace safety decals that are missing or have become illegible. See decal location figures that follow.
- Replaced parts must display the same decal(s) as the original part.
- Replacement safety decals are available **free of charge** from your distributor, dealer, or factory as applicable.

2.18.1 Decal Installation/Replacement

1. Decal area must be clean and dry, with a temperature above 50°F (10°C).
2. Decide on the exact position before you remove the backing paper.
3. Align the decal over the specified area and carefully press the small portion with the exposed sticky backing in place.
4. Slowly peel back the remaining paper and carefully smooth the remaining portion of the decal in place.
5. Small air pockets can be pierced with a pin and smoothed out using the decal backing paper.

2.18.2 Safety Decal Locations and Details

Replicas of the safety decals that are attached to the auger and their messages are shown in the figure(s) that follow. Safe operation and use of the auger requires that you familiarize yourself with the various safety decals and the areas or particular functions that the decals apply to, as well as the safety precautions that must be taken to avoid serious injury, death, or damage.

Figure 2. Hydraulic Cylinder Safety Decals

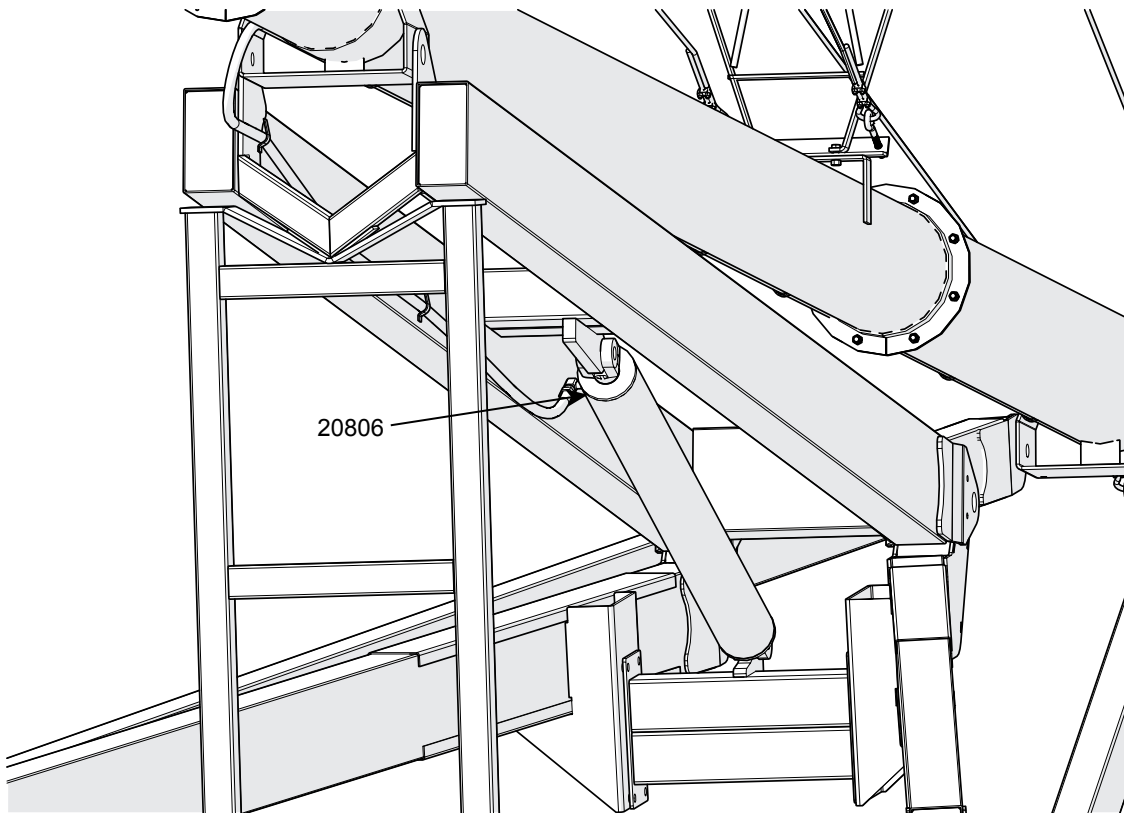

Figure 3. PTO and Tow Bar Safety Decals

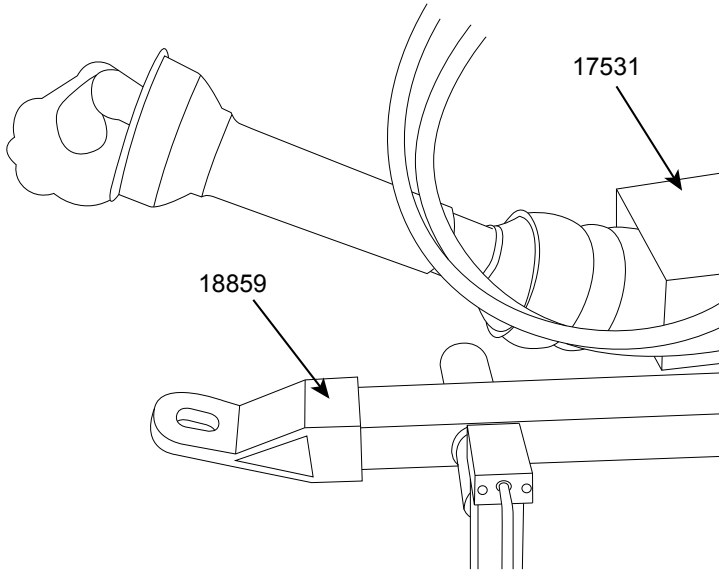

Figure 4. Auger Tube and Hopper Safety Decals

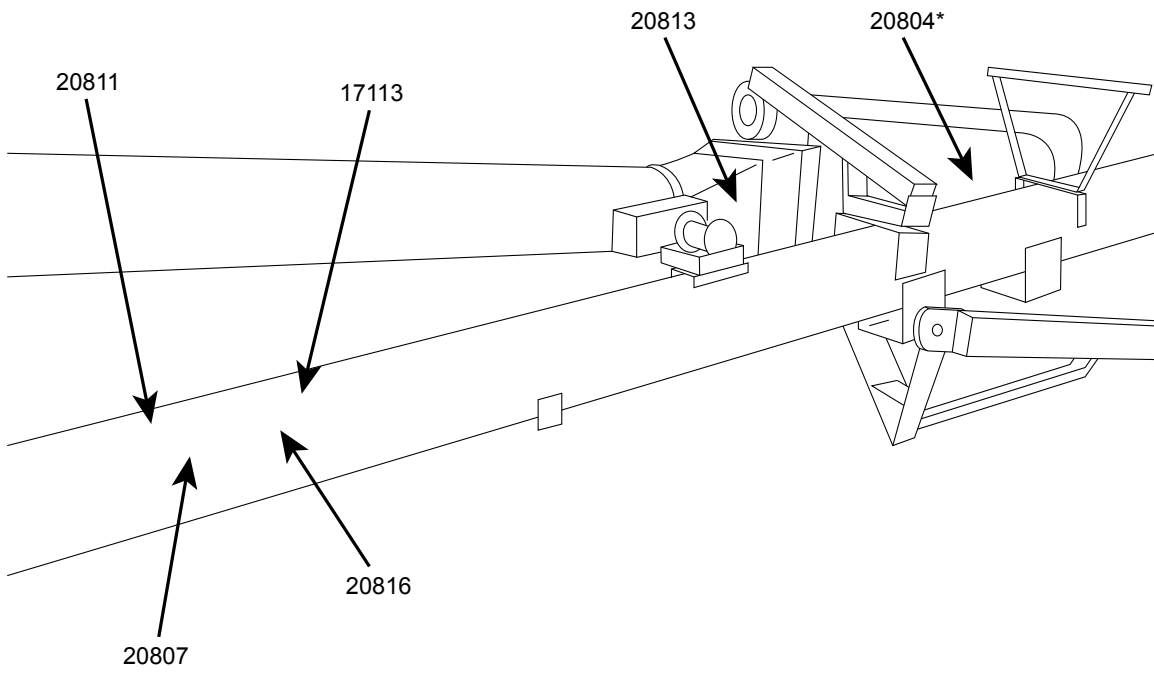

Figure 5. Boot Safety Decals

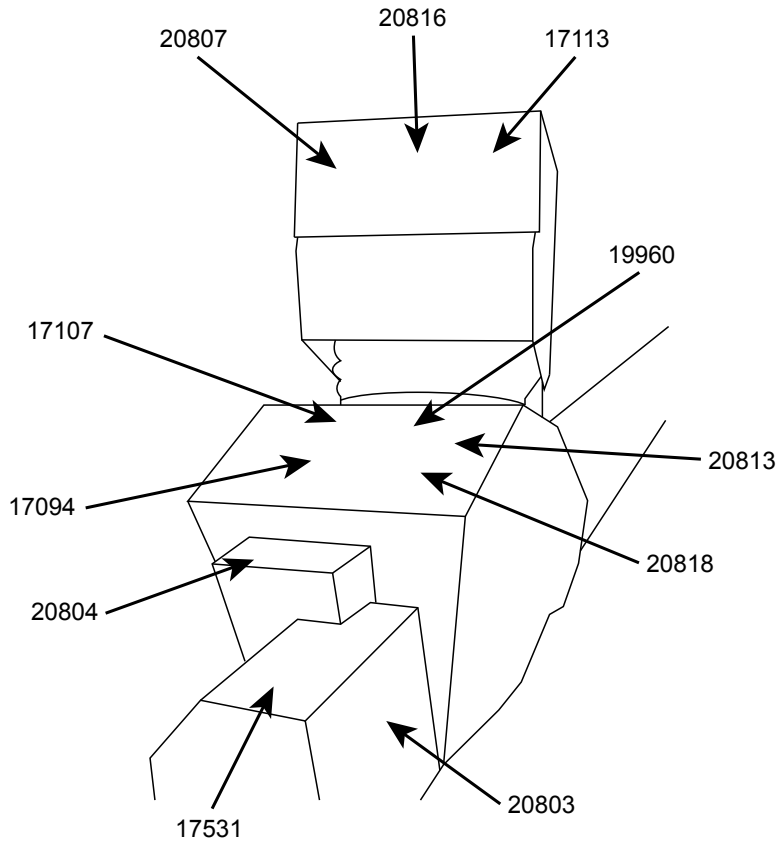

Figure 6. Roll-Over / Transport Safety Decal

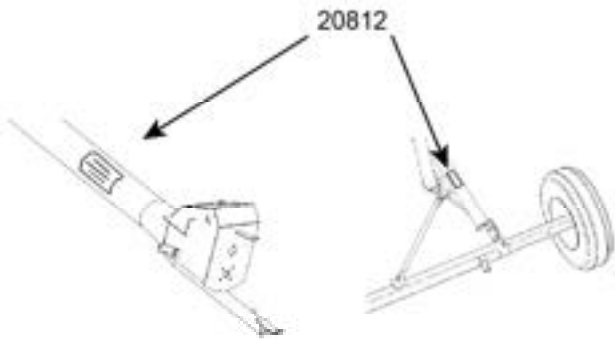

Table 1. Safety Decals





| Part Number | Description |
|-------------|--|
| 20813 | <div style="border: 1px solid black; padding: 10px;"> <div style="background-color: red; color: white; text-align: center; padding: 5px;">  DANGER </div> <div style="display: flex; justify-content: space-around; align-items: center; margin-top: 10px;">   </div> <div style="text-align: center; margin-top: 10px;"> <p>ROTATING FLIGHTING HAZARD</p> <p>To prevent death or serious injury:</p> <ul style="list-style-type: none"> • KEEP AWAY from rotating auger flighting. • DO NOT remove or modify auger flighting guards, doors, or covers. Keep in good working order. Have replaced if damaged. • DO NOT operate the auger without all guards, doors, and covers in place. • NEVER touch the auger flighting. Use a stick or other tool to remove an obstruction or clean out. • Shut off and lock out power to adjust, service, or clean. </div> </div> |
| 20818 | <div style="border: 1px solid black; padding: 10px;"> <div style="display: flex; justify-content: space-between; align-items: center; margin-bottom: 10px;">  <div style="background-color: red; color: white; text-align: center; padding: 5px;">  DANGER </div> </div> <div style="display: flex; justify-content: space-between;"> <div style="width: 45%;">  </div> <div style="width: 50%;"> <p style="text-align: center;">ROTATING PTO DRIVELINE</p> <p>To prevent serious injury or death:</p> <ul style="list-style-type: none"> • Keep body, hair, and clothing away from rotating PTO driveline. • Do not operate equipment unless all driveline, tractor, and equipment shields are in place and in good working order. • Make certain the driveline shields turn freely on driveline. • Make certain the driveline is securely attached at both ends. • Do not exceed specified operating speed (see operator's manual). • Keep u-joint angles small and equal. Do not exceed maximum recommended length for PTO driveline. </div> </div> </div> |

Table 1 Safety Decals (continued)



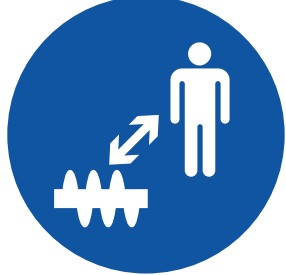

| Part Number | Description |
|-------------|--|
| 17094 | <div style="border: 1px solid black; padding: 10px;"> <div style="background-color: red; color: white; text-align: center; padding: 5px;">  DANGER </div> <div style="padding: 10px;"> <p>ROTATING FLIGHTING INSIDE</p> <p>To prevent serious injury or death, do not operate auger unless swing-hopper is securely attached to boot.</p> </div> </div> |
| 20816 | <div style="border: 1px solid black; padding: 10px;"> <div style="background-color: red; color: white; text-align: center; padding: 5px;">  DANGER </div> <div style="display: flex; justify-content: space-around; align-items: center; padding: 10px;">   </div> <div style="padding: 10px;"> <p style="text-align: center;">ELECTROCUTION HAZARD</p> <p>To prevent death or serious injury:</p> <ul style="list-style-type: none"> • When operating or moving, keep equipment away from overhead power lines and devices. • Fully lower equipment before moving. <p>This equipment is not insulated.</p> <p>Electrocution can occur without direct contact.</p> </div> </div> |
| 17113 | <div style="border: 1px solid black; padding: 10px;"> <div style="background-color: orange; text-align: center; padding: 5px;">  WARNING </div> <div style="padding: 10px;"> <p style="text-align: center;">TRANSPORT HAZARD</p> <p>To prevent serious injury or equipment damage, before towing:</p> <ul style="list-style-type: none"> • Lift up wheel frame completely and secure with safety chain. • Pull handle to disengage drive wheel motors. </div> </div> |

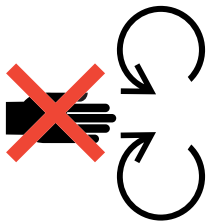
Table 1 Safety Decals (continued)

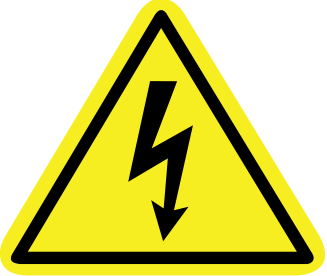
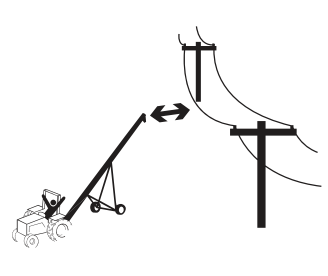

| Part Number | Description |
|-------------|---|
| 20804 | <div style="border: 2px solid black; padding: 10px;"> <div style="background-color: #f4a460; text-align: center; padding: 5px; border: 1px solid black;">  WARNING </div> <div style="display: flex; justify-content: space-around; align-items: center; padding: 10px;"> <div style="text-align: center;">  </div> <div style="text-align: center;">  </div> </div> <div style="text-align: center; padding: 10px;"> <p>ENTANGLEMENT HAZARD</p> <p>To prevent serious injury or death:</p> <ul style="list-style-type: none"> • Keep body, hair, and clothing away from rotating pulleys, belts, chains, and sprockets. • Do not operate with any guard removed or modified. Keep guards in good working order. • Shut off and lock out power source before inspecting or servicing machine. </div> </div> |

Table 1 Safety Decals (continued)



| Part Number | Description |
|-------------|---|
| 20811 | <div style="border: 2px solid black; padding: 10px;"> <div style="background-color: #f4a460; text-align: center; padding: 5px; border: 1px solid black;">  WARNING </div> <div style="display: flex; justify-content: space-around; margin-top: 10px;"> <div style="text-align: center;">  </div> <div style="text-align: center;">  </div> </div> <div style="text-align: center; margin-top: 10px;"> <p>UPENDING HAZARD</p> <p>To prevent death or serious injury:</p> <ul style="list-style-type: none"> • Anchor intake end and/or support discharge end to prevent upending. • Intake end must always have downward weight. Do not release until attached to tow bar or resting on ground. • Do not raise intake end above tow bar height. • Empty tube and fully lower before moving. </div> </div> |

Table 1 Safety Decals (continued)

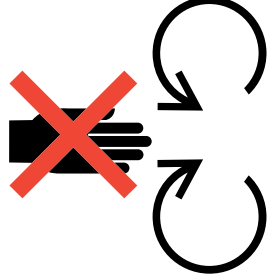

| Part Number | Description |
|-------------|--|
| 20807 | <div style="border: 2px solid black; padding: 10px;"> <div style="background-color: #f4a460; padding: 5px; text-align: center; font-weight: bold; font-size: 1.2em;">  WARNING </div> <div style="display: flex; justify-content: space-around; align-items: center; margin-top: 10px;"> <div style="text-align: center;">  </div> <div style="text-align: center;">  </div> </div> <div style="margin-top: 10px;"> <p>To prevent serious injury or death:</p> <ul style="list-style-type: none"> • Read and understand the manual before assembling, operating, or maintaining the equipment. • Only trained personnel may assemble, operate, or maintain the equipment. • Children and untrained personnel must be kept outside of the work area. • Do not modify the equipment. Keep in good working order. • If the manual, guards, or decals are missing or damaged, contact factory or representative for free replacements. • Lock out power before performing maintenance. • To prevent equipment collapse or upending, support equipment tube while disassembling certain components. • Follow grain storage structure manufacturer's warnings when loading and unloading. • Electric motors must be grounded. Disconnect power before resetting overloads. </div> </div> |

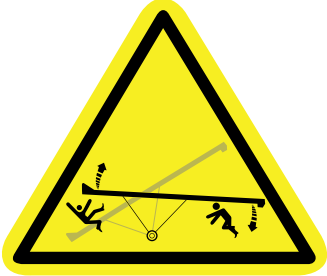
Table 1 Safety Decals (continued)







| Part Number | Description |
|--|---|
| 20803 (placed behind guard) | <div style="border: 1px solid black; padding: 5px;"> <div style="background-color: #f4a460; padding: 5px; text-align: center;"> WARNING</div> <div style="display: flex; justify-content: space-between; align-items: flex-start; padding: 5px;"> <div style="width: 25%;">   </div> <div style="width: 75%;"> <p>MISSING GUARD HAZARD</p> <p>To prevent serious injury or death, shut off power and reattach guard before operating machine.</p> </div> </div> </div> |
| 20812 (only included on augers 83' and longer) | <div style="display: flex; justify-content: space-between; align-items: flex-start; padding: 5px;"> <div style="width: 30%; text-align: center;">  </div> <div style="width: 30%; text-align: center;">  </div> <div style="width: 35%; border: 1px solid black; padding: 5px;"> <div style="background-color: #f4a460; padding: 5px; text-align: center;"> WARNING</div> <p>ROLLOVER / TRANSPORT HAZARD</p> <p>To prevent serious injury or death:</p> <ul style="list-style-type: none"> • Fully extend axles before raising tube. • Retract axles before transporting. </div> </div> |
| 20806 | <div style="display: flex; justify-content: space-between; align-items: flex-start; padding: 5px;"> <div style="width: 30%; text-align: center;">   </div> <div style="width: 65%; border: 1px solid black; padding: 5px;"> <div style="background-color: #f4a460; padding: 5px; text-align: center;"> WARNING</div> <p>HIGH PRESSURE FLUID HAZARD</p> <p>Hydraulic fluid can cause serious injury if it penetrates the skin. If it does, see a doctor immediately.</p> <ul style="list-style-type: none"> • Relieve system pressure before repairing, adjusting or disconnecting. • Wear proper hand and eye protection when searching for leaks. Use wood or cardboard instead of hands. </div> </div> |
| 17107 | <div style="border: 1px solid black; padding: 5px;"> <div style="background-color: #ffff00; padding: 5px; text-align: center;"> CAUTION</div> <p>To prevent personal injury or damage to equipment, close valve in lift cylinder hydraulic line after raising equipment into position.</p> </div> |

Table 1 Safety Decals (continued)

| Part Number | Description |
|-------------|---|
| 18859 | <div style="border: 1px solid black; padding: 5px;"> <p style="text-align: center; background-color: #0056b3; color: white; margin: 0;">NOTICE</p>  <p>Disconnect PTO driveline from tractor before moving equipment.</p> <p>If attached, driveline will bottom out, severely damaging the CV u-joint and lower flight shaft.</p> <p>See manual for maintenance.</p> </div> |
| 17531 | <div style="border: 1px solid black; padding: 5px;"> <p style="text-align: center; background-color: #0056b3; color: white; margin: 0;">NOTICE</p>  <p>To prevent damage during auger-to-tractor hookup:</p> <ul style="list-style-type: none"> • Follow dimensions above for correct auger-to-tractor hookup. • Auger must be on level ground and in full down position when measuring. • Adjust drawbar as needed. <p>See operation manual for complete details. </p> </div> |
| 19960 | <div style="border: 1px solid black; padding: 5px;"> <p style="text-align: center; background-color: #0056b3; color: white; margin: 0;">NOTICE</p> <p>To prevent damage, wheels must be free to move when raising or lowering equipment.</p> <p>When equipment is positioned, chock all wheels.</p> </div> |

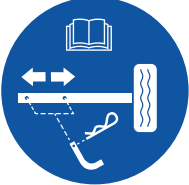
3. Features

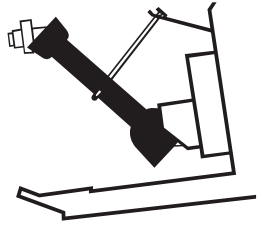
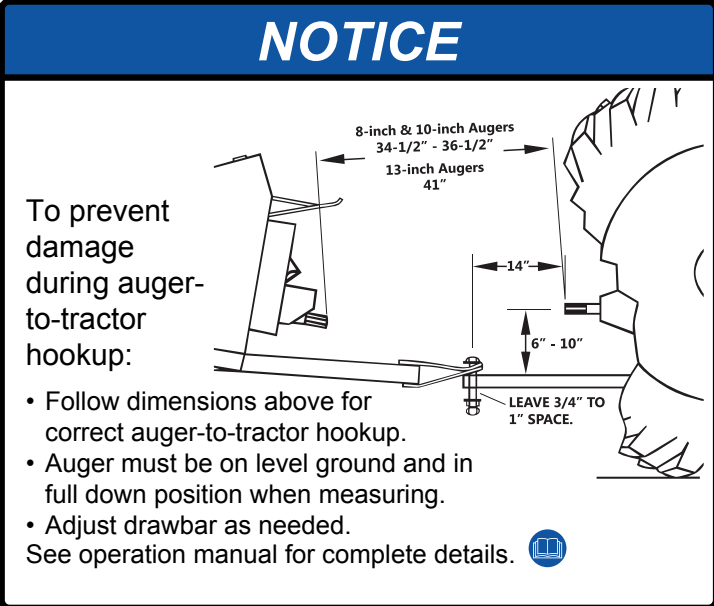
Read this section to familiarize yourself with the basic component names and functions of the auger.

Figure 7. Main Features

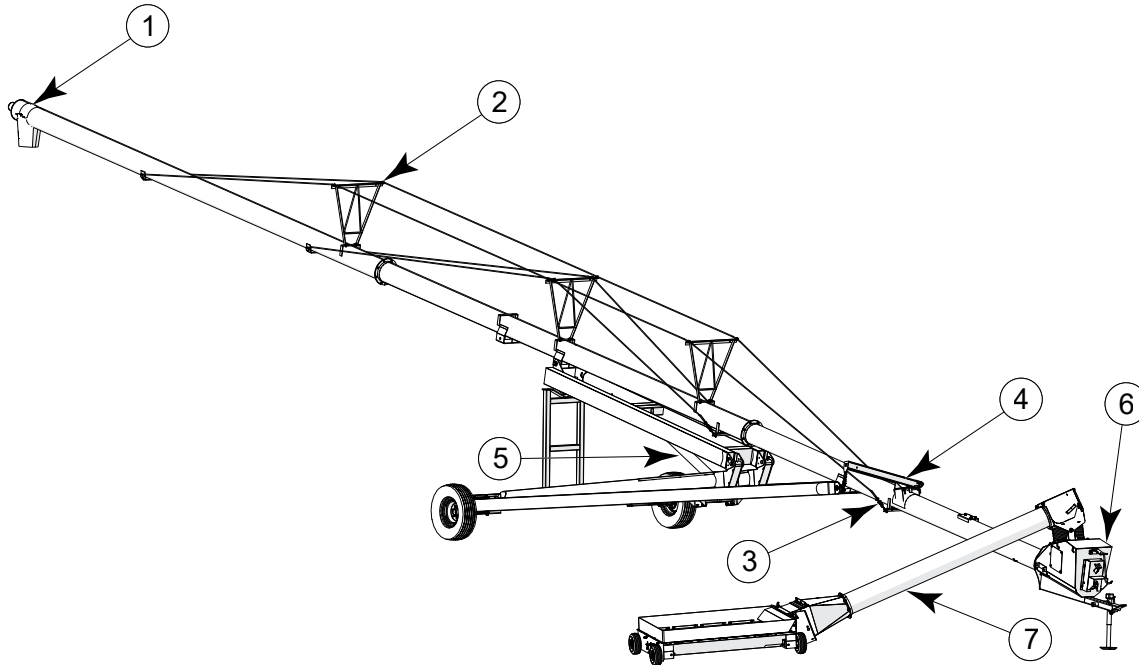

| Item | Description | Item | Description |
|------|------------------|------|--------------------|
| 1 | Discharge Spout | 5 | Hydraulic Cylinder |
| 2 | Truss Tower | 6 | Boot |
| 3 | Cable Adjustment | 7 | Swing |
| 4 | Lift Arm | | |

Figure 8. Grain Transfer Boot Features

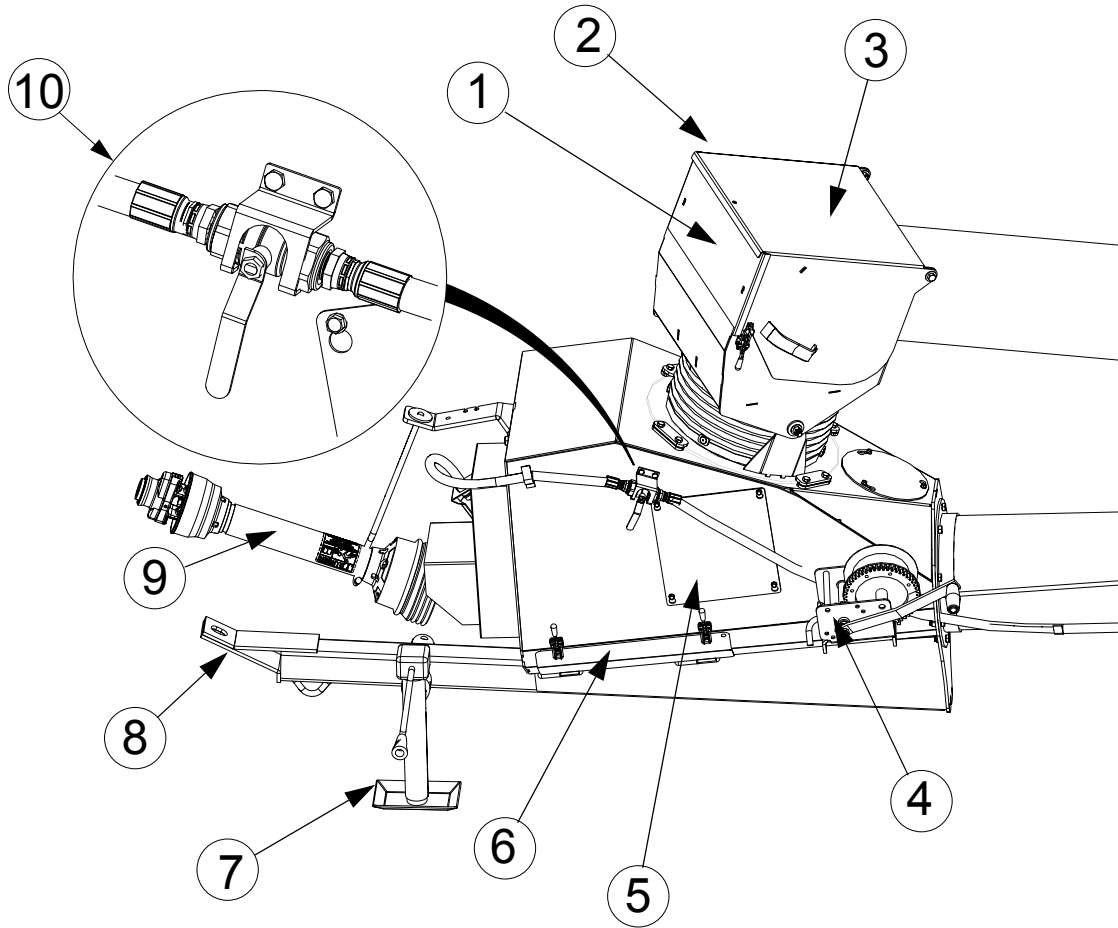

| Item | Description | Item | Description |
|------|--------------------------|------|-----------------|
| 1 | Overflow Panel | 6 | Clean-Out Hatch |
| 2 | Swing Arm Spout Head | 7 | Hitch Jack |
| 3 | Spout Head Service Cover | 8 | Hitch |
| 4 | Manual Winch (Hopper) | 9 | PTO Driveline |
| 5 | Grain Transfer Boot | 10 | Ball Valve |

Figure 9. Grain Hopper Features

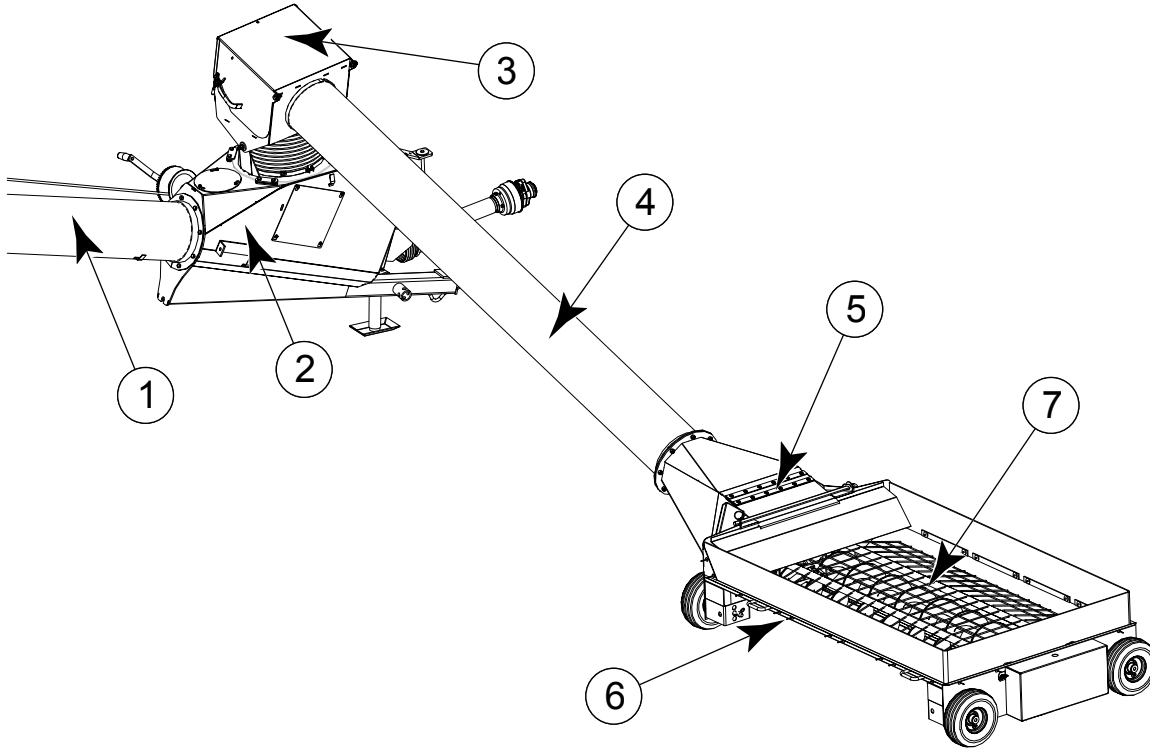

| Item | Description | Item | Description |
|------|-----------------|------|-----------------------------|
| 1 | Main Auger Tube | 5 | Maintenance Hatch |
| 2 | Boot | 6 | Hopper |
| 3 | Spout Head | 7 | Flights and Flight Guarding |
| 4 | Swing Tube | | |

4. Transport

 Before continuing, ensure you have completely read and understood this manual's Safety section, in addition to the safety information in the section(s) below.

4.1. Transport Safety

WARNING

- Check with local authorities regarding transport on public roads. Obey all applicable laws and regulations.
- Always travel at a safe speed, never exceeding 20 mph (32 km/h). Reduce speed on rough surfaces. Use caution when turning corners or meeting traffic.
- Yield to other drivers and allow faster traffic to pass.
- Make sure the SMV (slow moving vehicle) emblem and all the lights and reflectors that are required by local authorities are in place, are clean, and can be seen by all over-taking and oncoming traffic. Always use hazard-warning flashers on tractor/towing vehicle when transporting unless prohibited by law.
- Do not transport during times of limited visibility such as fog, snow, or heavy rain. Take extra precautions at night and at dusk.
- Keep others away from the transport vehicle and auger.
- Do not allow riders on the auger or towing vehicle during transport.
- Stay away from overhead obstructions and power lines when operating and transporting. Electrocutation can occur without direct contact.
- Fully lower the auger before transporting, and only raise when next to storage facility.
- Attach to a proper towing vehicle with a pin and retainer. Always attach safety chain(s).
- Do not raise the intake end above drawbar, upending may occur.
- Empty auger of all grain or seed before transporting. Transporting a full auger will place excessive loads on the tube, frame, axle, hitch, and tow vehicle.
- Do not transport on slopes greater than 20°.
- Do not transport with an under-inflated tire(s).
- If the auger wheels are partially or fully buried in snow or grain, failure to clear area around the wheels before transporting may cause damage to the auger or result in serious injury.

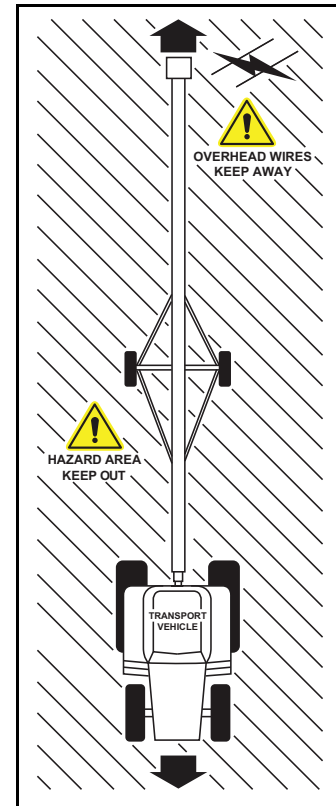

4.2. Transport Preparation

1. It is not recommended that the auger be transported faster than 20 mph (32 km/h). [Table 2](#) references the acceptable transport speed as per the ratio of tractor weight versus auger weight. See Specifications ([Section 9. – Specifications on page 65](#)) for auger weights.

WARNING A weight imbalance between the auger and the towing vehicle could result in a collision from reduced stability, handling, and braking ability.

2. Ensure the auger will clear any overhead obstructions or electrical wires prior to transporting. Refer to [Section 9. – Specifications on page 65](#) for the transport height of your auger.
3. Longer augers have a large turning radius. Allow ample room for turning as the discharge end may swing dramatically. Allow all oncoming traffic to pass before turning right or left.

WARNING A collision with an oncoming vehicle could occur if the auger discharge swings into the opposing lane.

Table 2. Speed versus Weight Ratio

| Road Speed | Weight or fully equipped or loaded implement(s) relative to weight of towing machine |
|------------------------|--|
| Up to 32 km/h (20 mph) | 1 to 1, or less |
| Up to 16 km/h (10 mph) | 2 to 1, or less |
| Do not tow if | More than 2 to 1 |

4.3. Connecting the Auger to the Towing Vehicle

This section provides an overview of how to connect the auger to the towing vehicle. For specific information on the components, refer to the applicable section.

Follow all safety precautions when transporting the auger and use a proper towing vehicle.

1. Fully lower the auger.
2. Disconnect the PTO driveline and hydraulics (as applicable) from the tractor.
3. Fully retract the wheel axles.
4. Place the hitch in transport position (if applicable).
5. Connect the auger to the tow vehicle with a hitch pin. Use a hitch pin that will not allow the auger to separate from the towing vehicle.
6. Connect the safety chain securely, forming a cradle to prevent the auger from digging into the road surface (should a breakaway occur). Do not use the safety chain if one or more links or end fittings are stretched, broken, damaged, or deformed.

Important

Use a safety chain with a load rating at least as high as the auger weight.

7. Move the jack into storage position.
8. Place the intake hopper into transport position.
9. Place the swivel jack (on side of hitch) in transport position and lock.

10. Use caution when transporting the auger over rolling terrain. In severe dips, the intake end may contact the ground.

Refer to [Section 9. – Specifications on page 65](#) for auger weight and hitch pin information.

Figure 10. Safety Chain and Hitch Connection

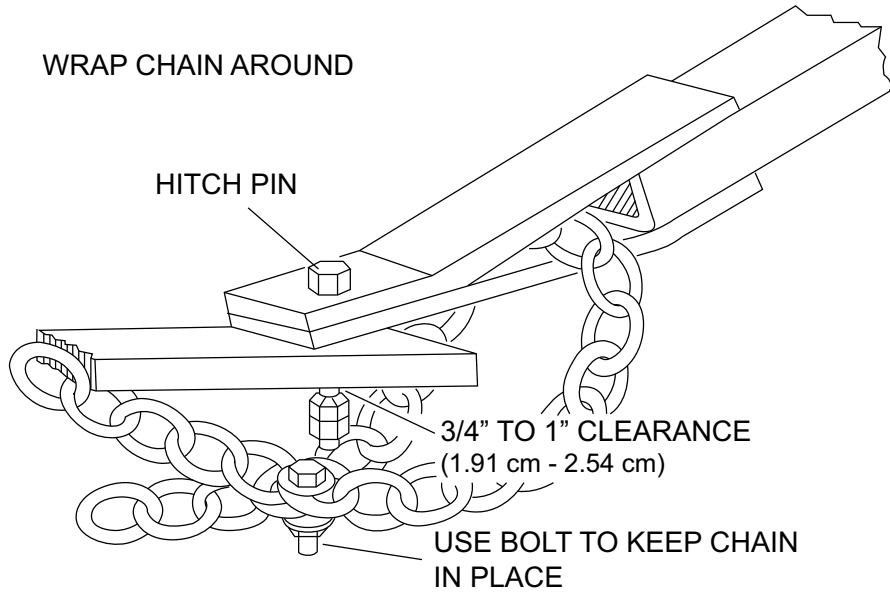
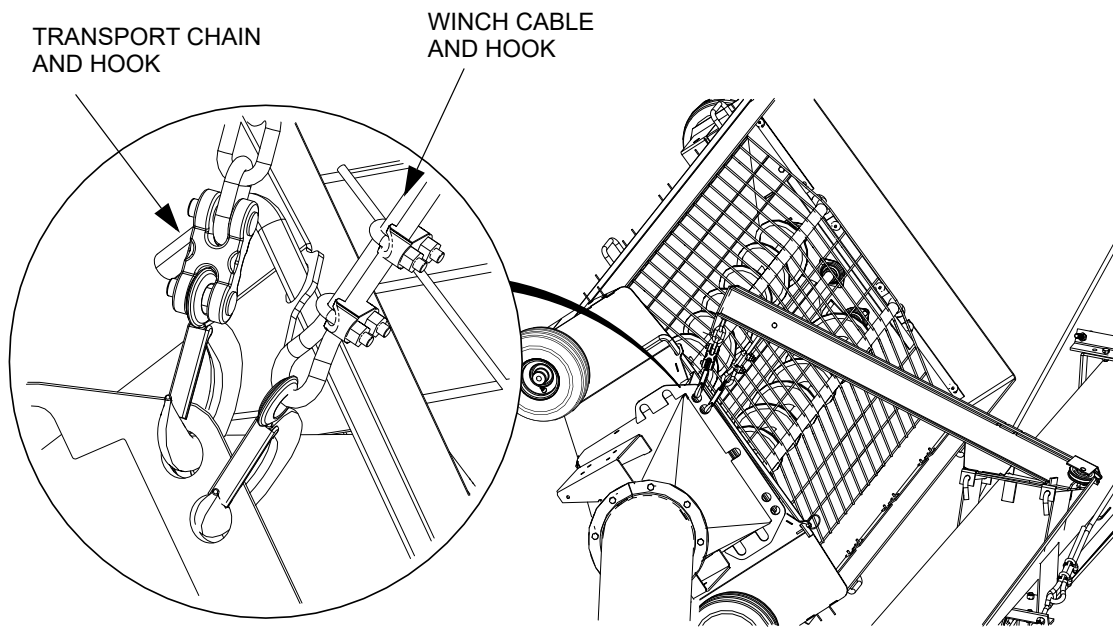

Figure 11. Hopper in Transport Position



5. Placement



Before continuing, ensure you have completely read and understood this manual's Safety section, in addition to the safety information in the section(s) below.

5.1. Placement Safety

WARNING

- The auger is not insulated, keep away from overhead power lines. Electrocutation can occur without direct contact.
- Anchor intake end before using.
- Place the auger on reasonably level ground before operating. The auger could topple if ground is too uneven.
- Chock the auger wheels after placement.
- Empty the auger before raising, lowering, or positioning.
- Check that wheels are free to move before raising or lowering the auger.
- Never attempt to increase height of the auger by positioning wheels on lumber, blocks, or by any other means.
- Do not permit anyone to stand beneath the auger when raising or lowering.
- Move the auger into position slowly. Do not unhitch and attempt to move by hand.
- Do not leave auger in raised position when not in use.

5.2. Positioning the Auger

Filling Bins

The auger is designed to be transported and operated without unhitching unit from tractor.

1. Disconnect the PTO driveline from the tractor and secure it in the transport saddle.

NOTICE

Failure to disconnect from the tractor will damage the PTO driveline.

2. Ensure that the tractor and auger are securely hitched together.

Important

Use a type of hitch pin (see Auger / Tractor Hookup section) that will not allow the auger to separate from towing vehicle.

3. Disconnect the safety chain from the intake hopper.
4. Before connecting the hydraulics, ensure that the quick-connect coupler on the auger and tractor is clean and free of dirt by wiping with a cloth.

WARNING

Dirt in the hydraulic system can damage the cylinder o-rings, causing leakage and the possible failure of the system and personal injury.

5. Connect hydraulic hoses, ensure connections are tight. Check for leaks, binding, flattening, kinks, or wear.
6. Fully extend wheel axles, see Extendable Axle Positioning.
7. Move the jack into storage position.

8. Move the auger into working position slowly. Do not unhitch and attempt to move the auger by hand.
9. Back the auger up to the storage facility while it is in its lowered configuration.
10. Raise the auger so it clears the storage facility. See **Raising and Lowering**.
11. Slowly back the auger up until the outlet is over the opening in the storage facility.
12. Slowly lower the auger to the bin.
13. Set the park brake on the tractor before dismounting, or chock its wheels.
14. Once the auger is in position, chock its wheels.
15. Lower the intake hopper to the ground, see Raising and Lowering the Intake Hopper.
16. See Operation for correct operating procedures.

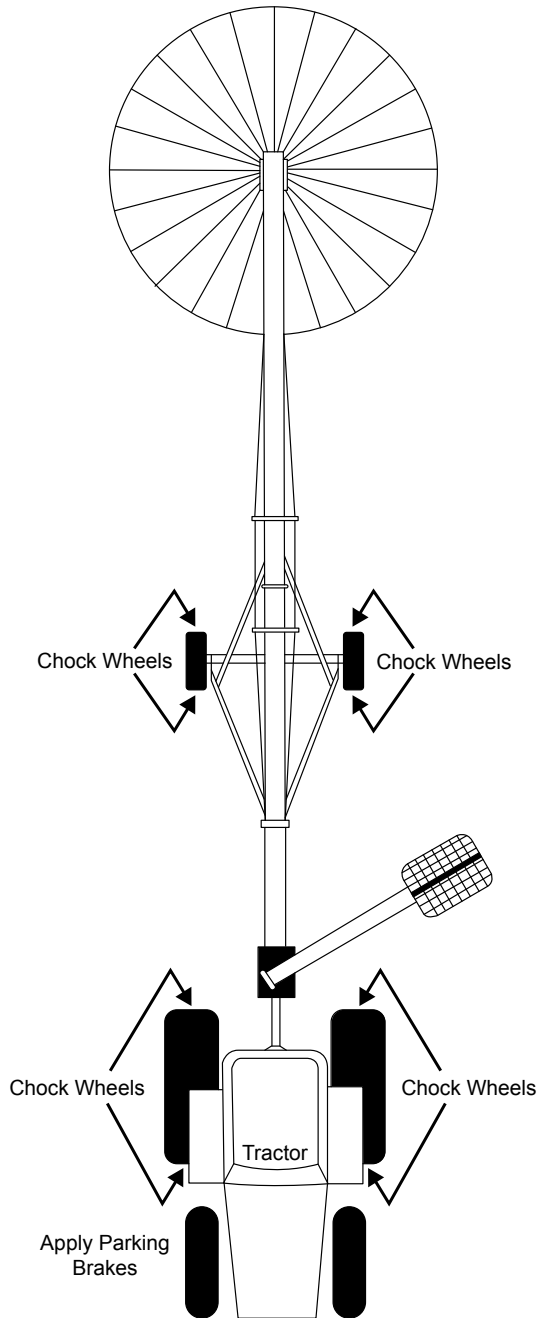
Figure 12. Auger Placement (Direct PTO Drive)

5.2.1 Raising and Lowering

The intake hopper must be off the ground when raising and lowering the auger.

Before using the hydraulic lift cylinder:

- The hydraulic cylinders are shipped without oil and must be charged with oil before operating the first time. See the Appendix section for charging instructions.
- Check that the hydraulic hoses are free from leaks, binding, flattening, kinks, or wear.

Raising

1. Before connecting the hydraulic hose, wipe the hose coupler clean.

NOTICE

Dirt in the hydraulic system can damage the cylinder o-rings and can cause leakage and failure of the system.

2. Connect the hydraulic hoses, ensure the connections are tight. Visually check for leaks, binding, flattening, kinks, or wear.
3. Open the ball valve on the hose connected to the cylinder.
4. Start tractor and idle at low rpm.
5. Engage hydraulic lever to power the cylinder.
6. Increase tractor rpm until desired rate of lift is reached.
7. Raise the auger to the desired height.
8. Close the hydraulic ball valve when the auger is fully raised.

NOTICE

Failure to close the ball valve may cause the frame to creep lower, potentially damaging the auger.

Lowering:

1. Reconnect the hydraulic hose coupler to tractor, if disconnected. Keep the tractor running while lowering the auger should the need arise to re-lift it.

NOTICE

Some augers are equipped with dual acting hydraulic cylinders, for these units the tractor must be running to pump oil to the upper chamber of the hydraulic cylinder(s) to prevent overfilling of the tractor reservoir.

2. Open the ball valve.
3. Open the tractor valve, feathering the control to prevent too rapid a descent.

Note

Once the valves are opened, the auger tube lowers by gravity. As the tube nears the full down position, the rate of descent will increase. Do not operate with the tractor valve fully open.

4. Turn off the tractor, and lock out the tractor power source.
5. Before disconnecting hydraulic couplers, relieve the hydraulic pressure.

WARNING

Disconnecting a hydraulic hose under pressure can result in serious injury.

5.3. Extendable Axle Positioning

➡ When equipped with extendable axles:

Important

Do not raise the auger unless the axles are in the extended position. Do not transport the auger unless the axles are in the retracted position.

WARNING

Rollover can occur if axles are not extended before raising the auger.

1. Ensure the auger is on level ground before attempting to extend or retract the axles. **The auger must be attached to tractor at all times.**

2. Using the jack supplied, insert it into one of the jack stubs located on one end of the axle. Jack must be secured to jack stub using pin (attached to jack).
3. Raise one side at a time. Raise until the tire clears the ground.
4. Remove the axle pin from the axle and position the axle as desired until the holes line up. Reinsert the axle pin and secure with hairpin. Lower the jack.
5. Repeat the process on the opposite side of the axle.

Figure 13. Typical Extendable Axle

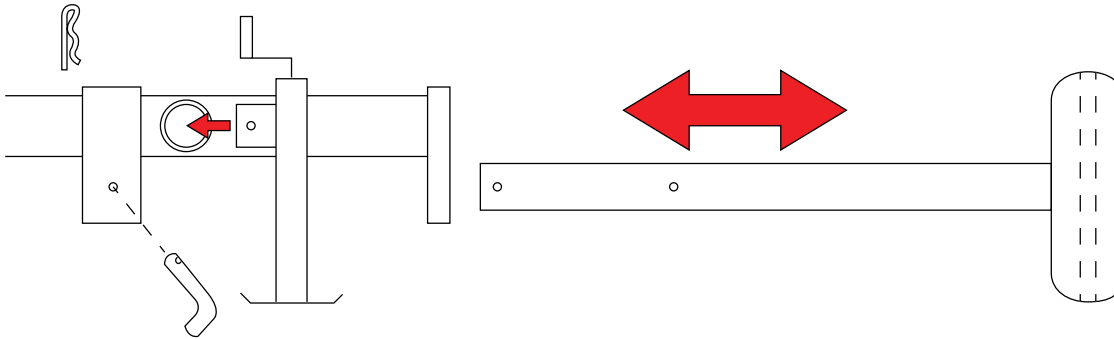

5.4. Auger-to-Tractor Hookup

The auger must be correctly connected to the tractor for all operations, including transport, raising, placement, and augering grain.

To secure the auger hitch to the tractor, use:

- a suitable bolt with 2 nuts locked against each other as a pin, or
- a hitch pin, a washer, and a hairpin.

A space between 3/4" (1.91 cm) and 1" (2.54 cm) must be provided between the bottom of the tractor drawbar and the top of the securing device on the pin.

The bolt/hitch pin must be 3/4" x 5" minimum.

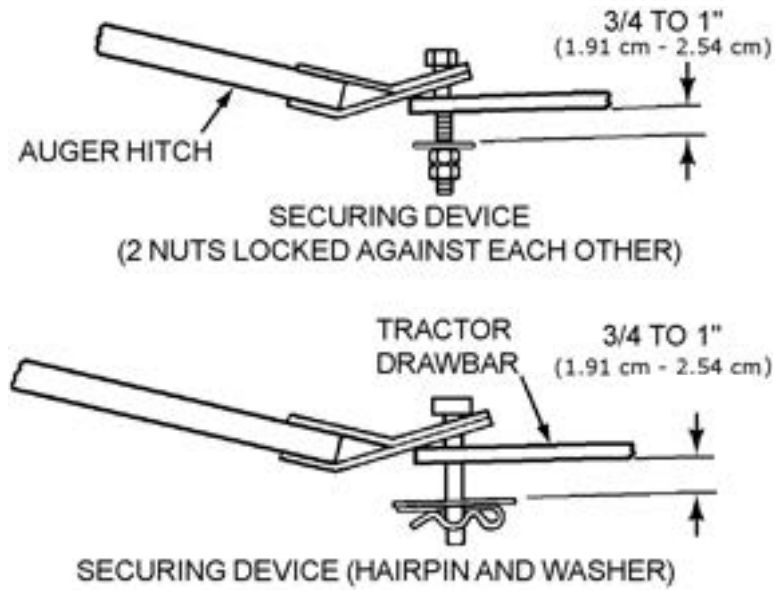
Figure 14. Hitching the Auger to a Tractor**Measurements Between Drawbar and Driveline**

Since the auger and tractor become an integral unit during transport, placement, and operation, the configuration and measurements between the tractor drawbar and the tractor PTO driveline are very important.

The ideal measurements are shown in [Figure 15 on page 38](#).

- Dimension (B) may range from 6" (15.2 cm) to 10" (25.4 cm) with 8" (20.3 cm) being ideal.
- If dimensions (A) and (B) on your tractor are as shown, then dimension (C), which is critical, will be correct.
- If (A) and (B) vary on your tractor from the recommended dimensions, consult the table below for potential problems and their solutions.

Figure 15. Measurements Between Drawbar and PTO Driveline

A 14" (35.6 cm)
 B 6" TO 10" (15.2 cm - 25.4 cm)
 C 34-1/2" - 36-1/2" (87.6 cm - 92.7 cm)
 (MUST BE TAKEN WITH AUGER ON LEVEL GROUND AND IN FULL DOWN POSITION) RAISE TRACTOR DRAWBAR IF NECESSARY TO MAINTAIN (B) DIMENSION OF 6" TO 10". (15.2 cm - 25.4 cm)

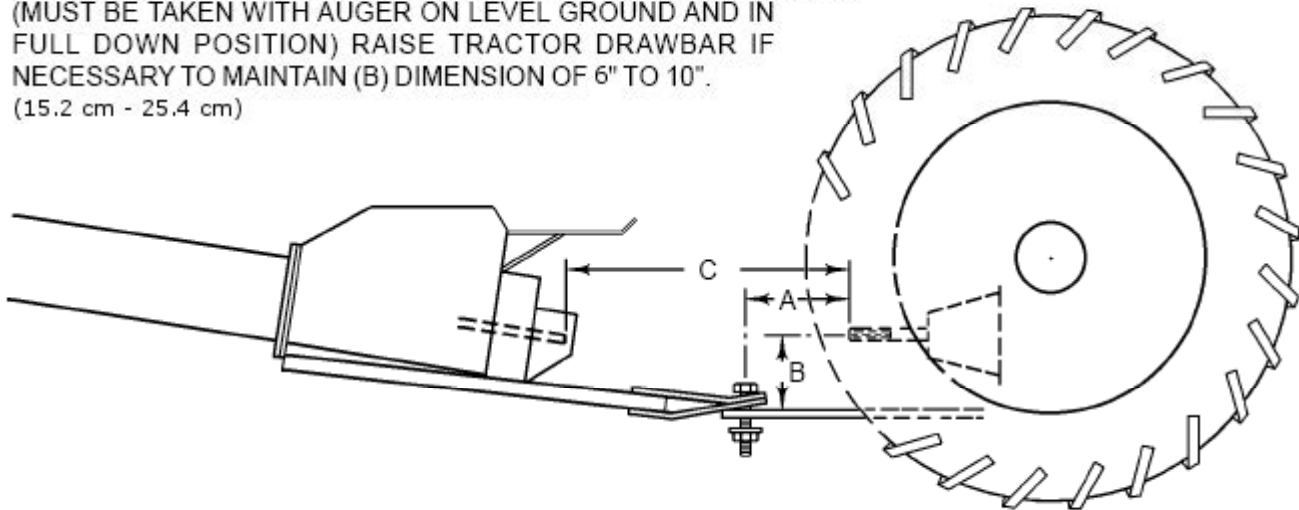

| Measurement | Problem | Solution |
|---|---|--|
| If (A) is less than 14" (35.6 cm) (C) will be less than the recommended 34-1/2" to 36-1/2" (87.6cm to 92.7cm). | The PTO driveline will bottom out when auger is in raised position, causing damage to the PTO driveline, the bearing, or the boot housing. | Pull out or lengthen the tractor drawbar as needed to make (C) 34-1/2" to 36-1/2" (87.6 cm to 92.7 cm) when the auger is in full down position. |
| If (A) is more than 14" (35.6 cm) (C) may be more than the recommended 34-1/2" to 36-1/2" (87.6 cm to 92.7 cm). | The PTO driveline will separate from the auger in the lowered position, causing damage to equipment and/or injury to personnel. | Shorten distance (C) to the recommended 34-1/2" to 36- 1/2" (87.6 cm to 92.7 cm) by attaching hitch to tractor drawbar at a point closer to the tractor PTO shaft. |
| If (B) is more than 10" (25.4 cm) (C) (between tractor PTO shaft and auger input shaft) shortens more quickly when auger is being raised. | The u-joint angle on the PTO driveline will be too severe in the raised position, causing the PTO driveline to bottom out before auger is fully raised. This will cause damage to the PTO driveline, flight shaft, bearing, and boot. | Raise the tractor drawbar until dimension (B) is within the recommended 6" to 10" (15.2 cm - 25.4 cm). |

5.5. Raising and Lowering the Intake Hopper

1. Attach the winch cable hook to the appropriate hopper lifting point.
2. Fully raise the hopper with intake side facing towards the main auger tube.
3. Secure the hopper with the transport chain and hook.

NOTICE

Do not operate auger with intake hopper in transport position. This will damage the u-joint.

Important

The hopper intake must face the main auger when in transport, see [Figure 16](#).

4. Ensure swing-away is empty before raising or lowering.
5. Do not permit anyone to stand near the swing-away when raising or lowering.

Figure 16. Hopper in Transport Position

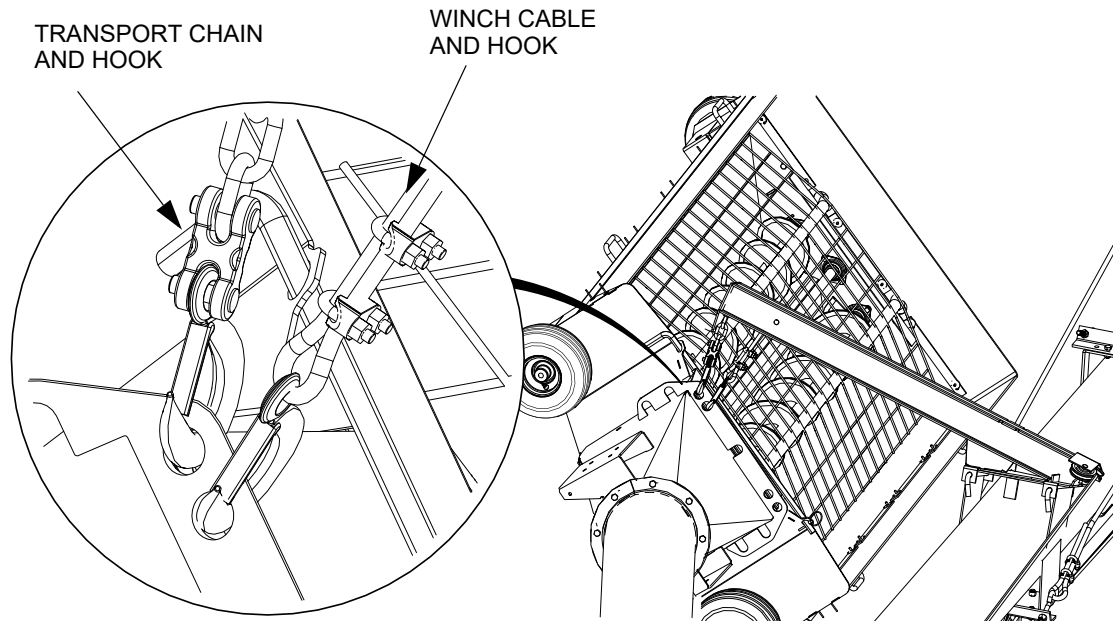

5.5.1 Swing-Away Hydraulic Winch Operation

➡ When equipped with a hydraulic winch:

1. Before connecting hose, wipe coupler clean.

NOTICE

Dirt in the hydraulic system can damage the winch motor and can cause failure of the system.

2. Connect hydraulic hoses, ensure connections are tight. Visually check for leaks, binding, flattening, kinks, or wear.
3. Check that cable anchor on winch drum is tight, cable clamps are secure, lift cable is seated in cable pulley, and inspect cable before operating. If damaged, replace immediately.
4. Always keep a minimum of 3 cable wraps on the drum with the swing-away hopper fully lowered.
5. Start tractor and idle at low rpm. Engage hydraulic lever to power winch. Test the direction of rotation of winch to ensure drum is moving in the direction required. Increase tractor rpm until desired rate of lift or descent is reached.
6. Do not touch, grab, or guide cable while equipment is being raised or lowered.

CAUTION

Do not continue to supply power to winch when swing-away is fully up. Damage to equipment and/or personal injury could result.

5.6. Grain Hopper Positioning

The low-profile grain hopper is designed to be rolled into position to receive grain for transfer through the boot to the auger discharge spout. Ground clearance can be adjusted by raising or lowering the position of the hopper wheel axles.

The grain hopper must be lifted and secured for transport using the hopper lift arm, hydraulic winch, and transport chain and hook. The hopper lift arm can be reconfigured for lifting on either side of the auger.

5.6.1 Electric Power Swing Operation

➡ The Electric Power Swing is an optional component for some auger models.

Remote transmitters are pre-programmed from the factory — to reprogram your remote (or to add additional remotes), please see the Appendix.

You can register more than one remote transmitter to a single Power Swing. However, it is not recommended to register one remote transmitter to multiple Power Swings.

Figure 17. Electrical Cables

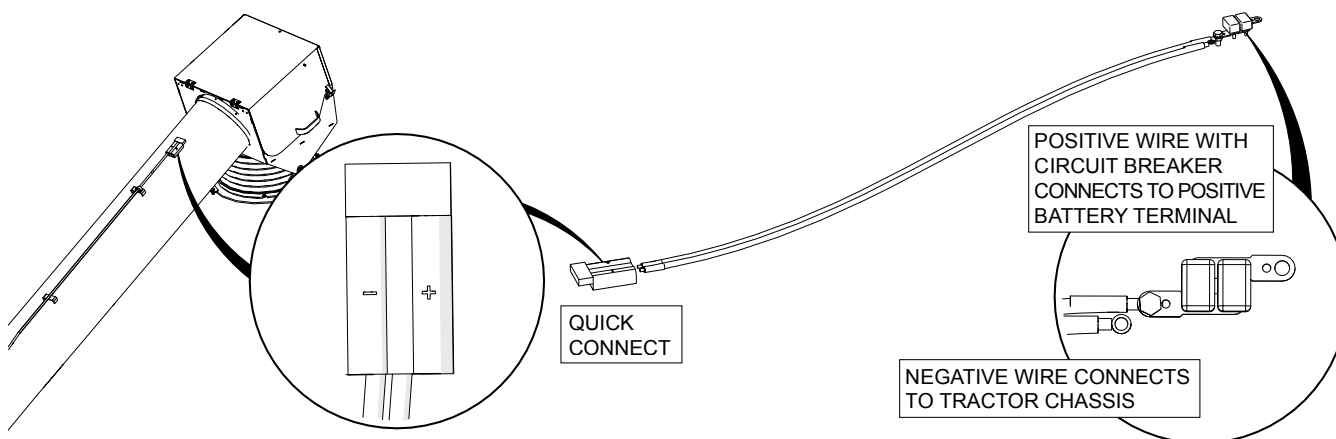

1. Connect the end opposite the quick-connect to the battery and chassis ground using the 5/16" lugged connectors supplied with the kit:
 - a. Attach the positive wire directly to the positive terminal on the tractor battery (the positive wire has a circuit breaker on it).
 - b. Attach the negative wire to a tractor chassis ground point (assuming that the tractor battery is also grounded to the chassis).

NOTICE

If these electrical cables are not hooked up properly the electric controller will be damaged.

2. Attach the receiver cable quick connect to the tractor wire harness quick connect.
3. On the high end of the Power Swing remote receiver box, flip the power switch (Figure 18) to the ON position.

Table 3. Power Swing Receiver Box

| Item | Description |
|------|------------------|
| 1 | Receiver Box |
| 2 | Power Switch |
| 3 | Direction switch |

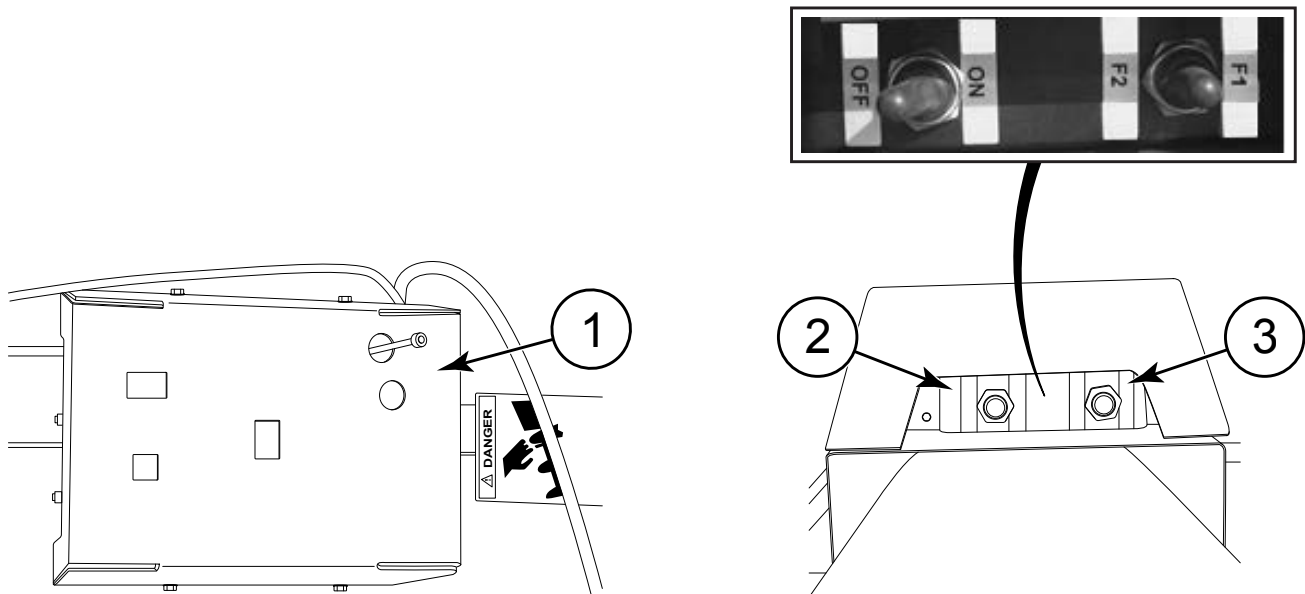
Figure 18. Power Swing Receiver Box**For Receiver Box Operation:**

1. Using the direction switch, move the switch in the desired direction of travel (either F1 or F2).
2. Once finished moving the hopper, release the switch to stop operation (it should return to the neutral position).

Figure 19. Power Swing Remote Transmitter**For Remote Transmitter Operation:**

1. Push the green button (no symbol) to turn the remote ON ([Figure 19](#)).
2. Push the yellow directional buttons (marked with arrows) located below the ON/OFF buttons in the direction you want the hopper to move ([Figure 19](#)).
3. If this does not work:
 - a. Push the red button (with an exclamation mark) to turn the remote OFF.
 - b. Then push the green button (no symbol) to turn the remote back ON.
4. Operate the remote as outlined above, using the two yellow directional buttons (marked with arrows) located at the bottom of the remote to move the hopper as desired.

5.6.2 Hydraulic Power Swing Operation

- ➡ 1. Ensure that the valve is in the proper configuration (open-center or closed center). Refer to [Section 10.4 – Open/Closed-Center Valve Conversion on page 69](#).
2. Adjust the tractor's output flow using the flow control lever to achieve 4-5 gpm. This will ensure a controlled speed.
3. Put the lever that controls your tractor hydraulics in the detent position where the hydraulics stay engaged all the time.
4. In order to activate the Power Swing:
 - a. Push the right-side control lever on the Power Swing valve control assembly to raise the hopper.
 - b. Use the left-side control lever to move the hopper in the desired direction of travel.
 - c. Once finished moving the hopper to the desired position, use the right side control lever to lower the hopper.

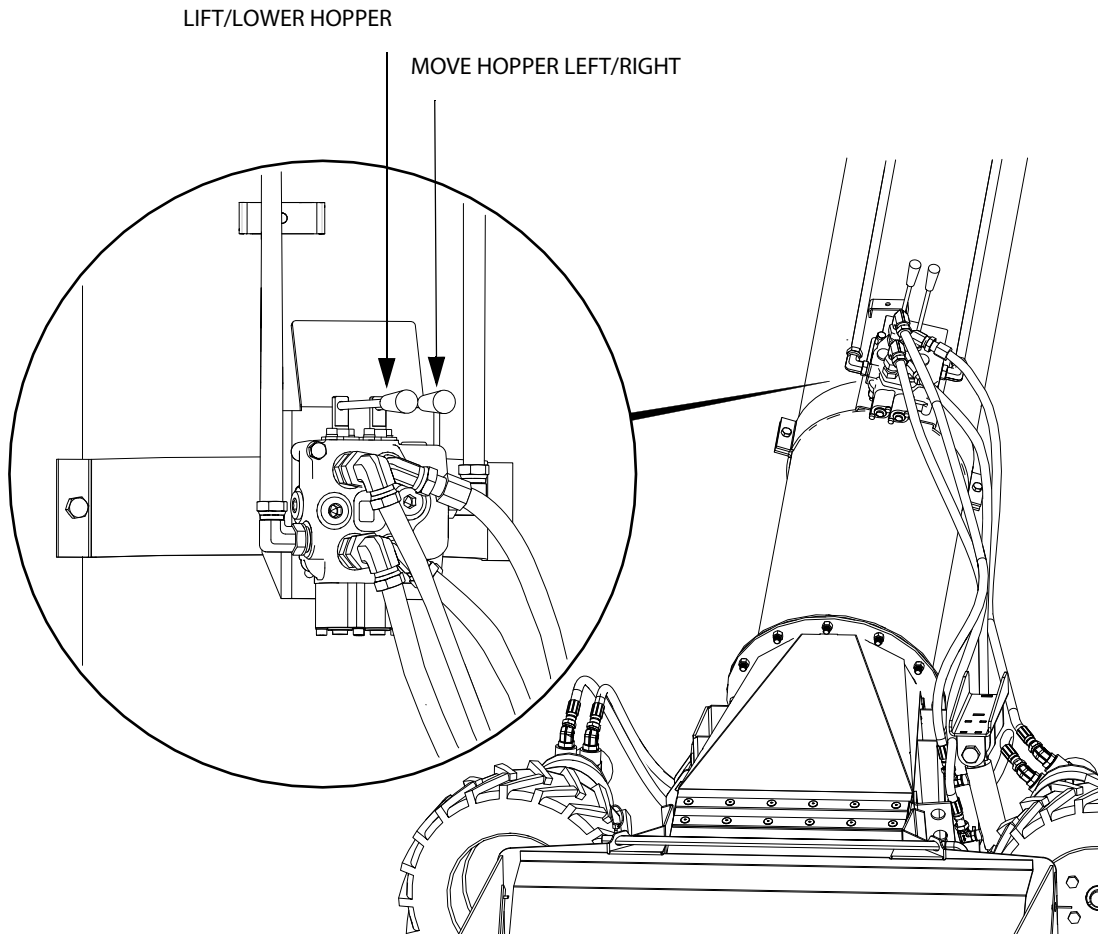
Figure 20. Control Valve Lever Functions

5.7. Positioning the Tractor for Right Angle Drive Operation

Before setting up for right angle drive operation, the auger must first be positioned at the bin with a tractor with the auger wheels securely chocked, and the ball valve for lifting must be closed.

➡ The right angle drive is an optional component.

1. Position hitch jack with a board underneath, then raise the auger hitch slightly.
2. Relieve pressure in the hydraulic hose, then disconnect from tractor and place in the auger's hose rack.
3. Remove the safety chain and hitch pin, then move the tractor.
4. Attach the support leg as shown in [Figure 22](#), and secure with a pin and hairclip.
5. Place a board under the support leg if needed, then lower the hitch jack until the auger's intake weight is supported with the support leg. Place the hitch jack into the transport position. See [Figure 21](#).
6. Position the tractor at a right angle to the auger intake; apply the parking brake, and chock the tractor wheels.
7. Securely connect the non-separable PTO driveline to the tractor. Make sure all guards and master guards are in place.

- 8. Do not exceed the maximum PTO operating length of 80" (2.03 m) or a maximum angularity of 15° from the ideal 90° drive angle.

Figure 21. Tractor Position for Right Angle PTO Drive (Left Side Drive Configuration)

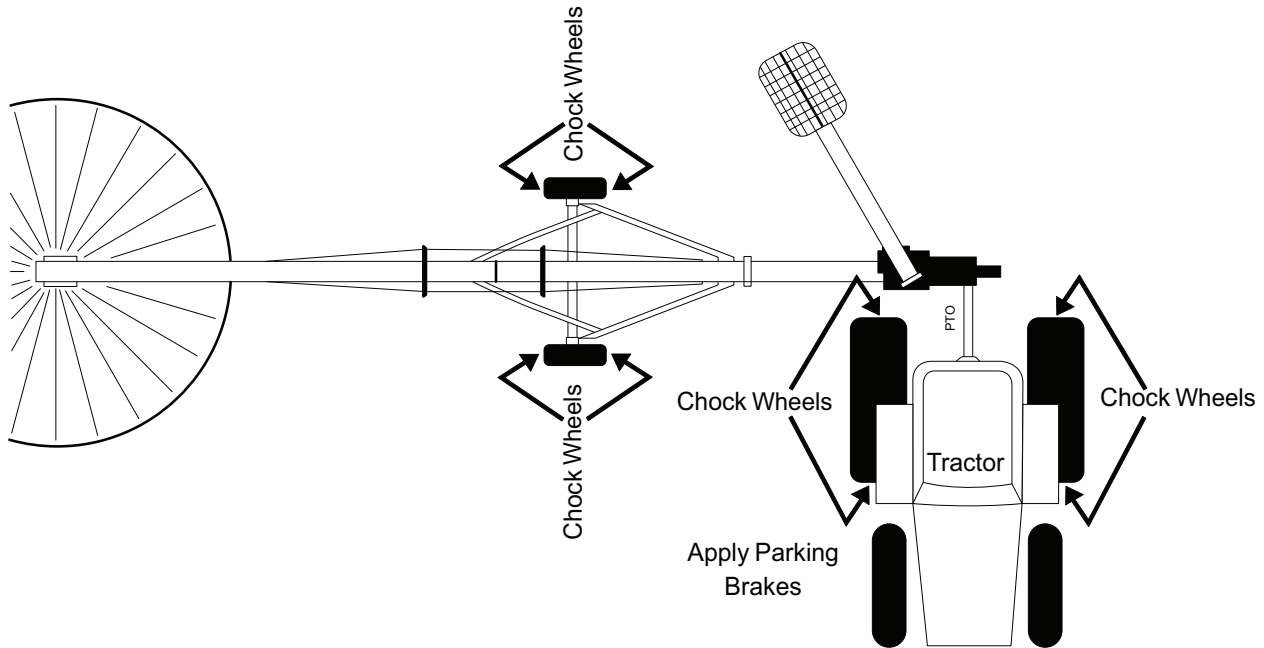
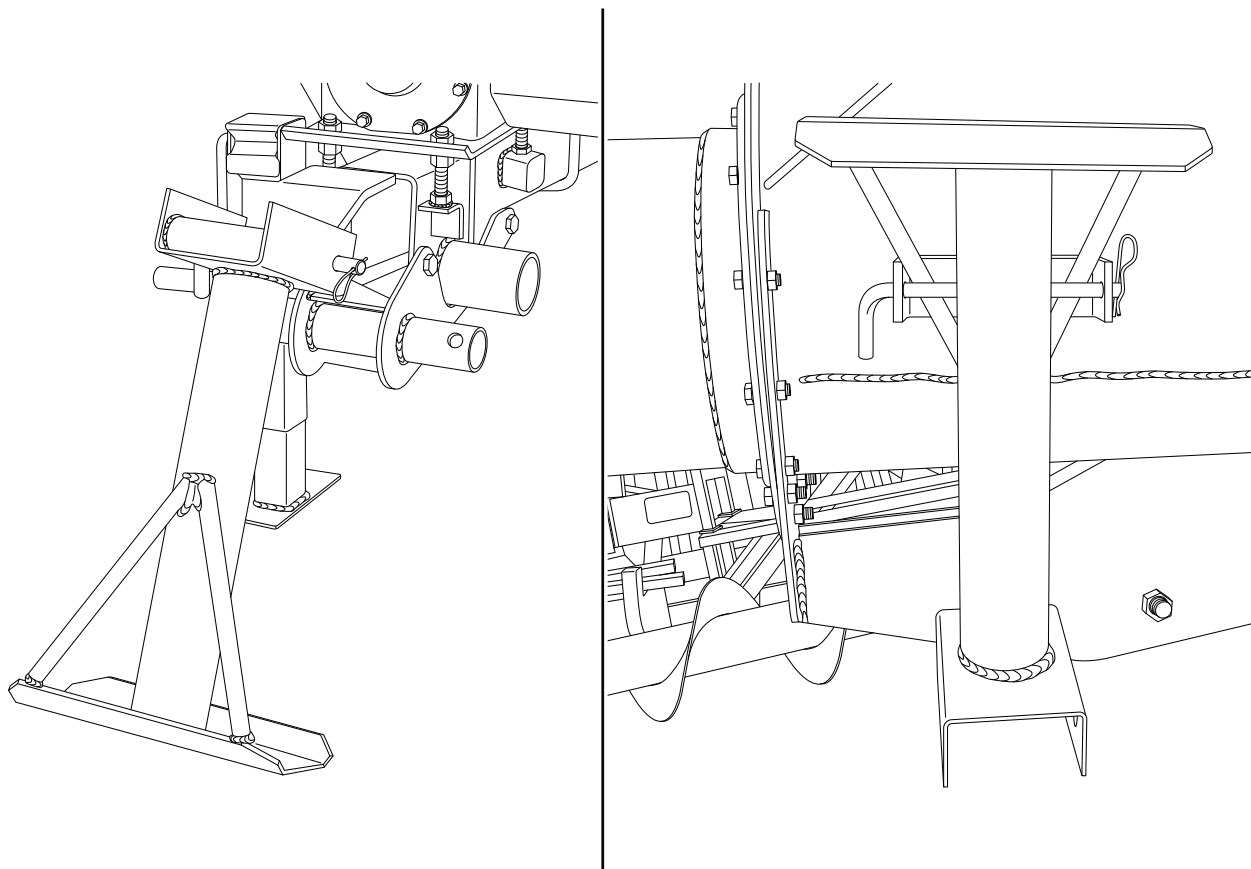

Figure 22. Right Angle Drive Support Leg Working (left) and Storage Positions (right)



6. Operation



Before continuing, ensure you have completely read and understood this manual's Safety section, in addition to the safety information in the section(s) below.

6.1. Operation Safety

WARNING

- Keep away from rotating and moving parts, including the auger/mixer flighting, drive components, shafts, and bearings.
- Do not enter the grain or truck while the auger is operating.
- Always operate with guards, covers, and shields in place.
- Have another trained person nearby who can shut down the equipment in case of accident.
- Keep the work area clear of bystanders.
- Keep the work area clean and free of debris.
- Ensure maintenance has been performed and is up to date.



Refer to your operation manual for specific operating and safety information for your .

6.2. Start-up and Break-in

Check the following during the first hours of operation.

1. Check that the auger intake and discharge areas are free of obstructions.

NOTICE

Foreign objects can damage the auger. Remove any obstructions from the intake and discharge areas before operating the auger.

2. Visually inspect the auger, see Visual Inspection in Maintenance Section.
3. Check tightness of all bolts/nuts, fasteners, and hardware (re-torque if necessary).
4. Ensure adequate power is supplied to operate the auger, see [Section 9. – Specifications on page 65](#).
5. Start the tractor and idle at low rpm. Slowly engage the PTO drive. Refer to PTO Drive Operation.
6. Gradually begin feeding grain into the hopper, bringing the tractor PTO drive to roughly half speed. Do not overfeed the hopper on initial loads; keep the feed of grain at about half capacity.
7. Be aware of unusual sounds. If any are heard, determine the source and stop the auger. Lock out the power and correct the problem before resuming work. If you are unsure of the problem or procedure, contact your local dealer.

Note

The auger may run rough until the tube is polished.

8. After the auger tube is polished and runs fairly smoothly, proceed to unload at the specified full PTO speed. Do not exceed the specified full PTO speed (see [Section 9. – Specifications on page 65](#)).
9. Do not run the auger for long periods of time without material because it increases wear. Try to run only when moving material.
10. Stop the auger when it is empty of grain, lower fully and lockout power.

Important

After the initial start-up and inspection, the auger should be shut down and visually inspected (see Maintenance Section) after approximately ten hours of operation.

6.3. Operation - PTO Drive

1. Attach the PTO driveline securely to the tractor and confirm the connection to the auger shaft is secure.
2. Confirm the PTO driveline rotating shield and other shields/guards are in place and in good working order.
3. Align the tractor axis with the auger input shaft to minimize the angles of the universal joints on the PTO driveline.

Important

Check that the PTO does not exceed the maximum operating angle, refer to [Section 9. – Specifications on page 65](#).

4. Confirm that the auger-to-tractor PTO hookup distances are set as required.
5. Ensure the PTO drive on the tractor is in the off position before starting the tractor.
6. Start tractor engine at low idle, slowly engage the PTO with the tractor idling to prevent unneeded stress on the drive components and shear bolts.
7. If everything is operating normally, start running grain through the auger and increase the tractor PTO to the specified full speed to produce the required flow.
8. To shut down, reduce the speed to low idle and lock out the PTO.
9. Disconnect the PTO driveline from the tractor and secure it to the PTO transport saddle with the safety chain and keep it in transport saddle when transporting.

When raising or lowering the auger:

Disconnect the PTO driveline.

When starting under load:

If restarting the auger under load (tube is full), engage the PTO with the tractor idling.

NOTICE

Engaging the PTO at high engine speed under load will result in equipment damage.

Shear Bolts:

If a shear bolt in the PTO driveline fails, shut down and lock out the tractor to replace the shear bolt. Ensure that the shear point is through the shank of the bolt, not the threads. Refer to [Section 9. – Specifications on page 65](#) for shear bolt sizes.

6.3.1 PTO Operation — Forward and Reverse Modes

WARNING

Shut down and lock out power before changing to forward or reverse modes.

To Operate in Forward Mode:

The stub spline on the PTO driveline must be inserted into the forward spline coupler and securely locked into place.

To Operate in Reverse Mode:

1. Insert the stub spline on the PTO driveline into the reverse spline coupler, see [Figure 23](#), making certain it is securely locked into place.
2. Remove the cleanout cover before operating in reverse mode.
3. Operate the auger slowly in reverse for a short period of time. **Do not exceed 100 RPM.**
4. When the boot is nearly full, shut off and lock out power, then clean out any remaining grain from the boot using a stick. Do not use your hands. Repeat the above procedure as needed.

Note

Reverse mode is intended to assist in clean out of the auger. It is not designed to unplug the auger. When operating in reverse mode, the auger must be monitored to prevent the boot from overflowing.

NOTICE

Excessive back pressure will cause extensive damage to the auger which is not covered by warranty.

Figure 23. Forward and Reverse PTO Positions

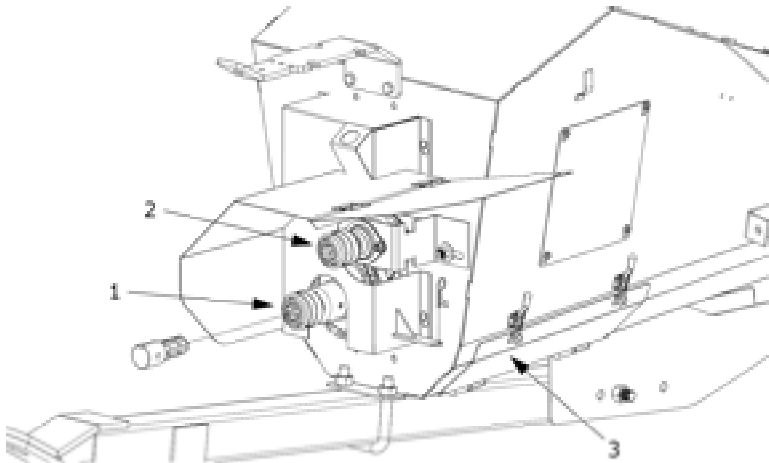

| Item | Description |
|------|------------------|
| 1 | Forward Position |
| 2 | Reverse Position |
| 3 | Cleanout Cover |

6.4. Safety Discharge Door

The auger is equipped with a safety discharge door which will allow grain to overflow out of the swing-away discharge spout and prevent the main auger tube from plugging. This will happen when the auger is at a steeper angle because the capacity of the auger will decrease as the tube angle increases. If the safety discharge door opens, decrease the flow of grain to the swing-away intake hopper or lower the angle of the auger tube.

6.5. Emergency Shutdown

In an emergency situation:

1. Stop or shut down the power source immediately and lock out all power.
2. Stop the flow of material (if applicable).
3. Ensure the machine components come to a stop before inspecting.
4. Correct the emergency situation before resuming work.

6.6. Restarting with a Full Tube

When the auger is shut down inadvertently or due to an emergency, the tube may still be filled with grain.

1. With the power source locked out, remove as much of the grain as possible from the tube and intake using a shop vacuum or other tool. Do not use your hands.

NOTICE

Starting under load may result in damage to the auger.

2. If guards or covers have been opened or removed, close or replace them before restarting the unit.
3. If the auger tube is full of grain, do not restart at full speed. Engage the drive at low power, gradually increasing until normal operating speed is reached.
4. Once the auger has been started, you may resume normal operation.

6.7. Bin Level Indicators

A full bin will cause auger to plug, which can damage the flighting and other drive components. Installing grain-level indicators on your bins will allow you to monitor bin filling and help prevent damage to your auger.

6.8. Use of Grain Spreaders

Many grain spreaders cannot handle the large capacity of some augers and can cause the auger to plug, damaging the flighting and other drive components. This type of damage is not covered by warranty. To avoid this:

- Make sure spreader is turned on and operating.
- When using a flex down spout, center auger spout above spreader and do not lower auger spout into spreader.
- Suspend the spreader lower from bin ceiling leaving extra room for excess grain to flow over the spreader.
- Get a larger spreader, if available.
- Remove the spreader.

6.9. Shutdown

When operation has been completed:

1. Once auger is clear of grain, lock out the power source.

2. Clean out any remaining grain from the auger with a vacuum or sweep out.
3. Clean the entire work area.
4. Remove anchors, supports, and chocks.
5. Disconnect the PTO driveline, and raise the intake hopper off the ground.
6. Move the auger away from the bin, and ensure that there is nothing under the auger that would make contact when the auger tube is lowered.
7. Lower the auger, refer to Raising and Lowering.
8. Lift the intake feed hopper fully into transport position, and secure it with the safety chain, refer to Raising and Lowering the Intake Hopper.

6.10. Operating the Auger with Fertilizer

If auger has been used to move fertilizer, it should be cleaned out to prevent corrosion. The easiest way to prevent corrosion is to run a load of grain through it after moving fertilizer or clean the machine as noted in the Maintenance section.

6.11. Storage

After the season's use, the auger should be thoroughly inspected and prepared for storage. Repair or replace any worn or damaged components and perform maintenance as described in the Maintenance Section to prevent any unnecessary downtime at the start of the next season.

To ensure a long, trouble-free life, this procedure should be followed when preparing the unit for storage.

1. Remove all residual material from the hopper and the tube.
2. Wash the auger thoroughly using a water hose or pressure washer to remove all dirt, mud, debris, or residue.
3. Inspect all moving or rotating parts to see if anything has become entangled in them. Remove any entangled material.
4. Touch up all paint nicks and scratches to prevent rusting.
5. Check tire pressure and inflate. For inflation pressure, refer to [Section 9. – Specifications on page 65](#).
6. Inspect the auger for cracks, tightness of fittings and fasteners, hydraulic hose cracks (if applicable). Have required repairs performed to replace worn or damaged components.
7. Store in an area that is dry, level, free of debris, and away from human activity. Store inside if possible.
8. Chock wheels.
9. Support intake on blocks to eliminate prolonged contact with the ground.
10. Clean and lightly lubricate the spline on the PTO driveline. Cover the PTO driveline with a plastic bag to protect it from the weather and place it in the transport saddle.
11. Lower the auger fully for storage.
12. Place the swing-away hopper in transport position, ensuring there will be adequate drainage of any moisture.

Power Swing**➡ When Equipped:**

1. Raise wheels to full up position.
2. Clean out axle assembly and lubricate chains with a light coating of oil.
3. Inspect unit for damage and note any repairs required. Order replacement parts from your dealer.
4. Check tire pressure and inflate according to tire side-wall recommendations.

7. Maintenance



Before continuing, ensure you have completely read and understood this manual’s Safety section, in addition to the safety information in the section(s) below.

7.1. Maintenance Safety

WARNING

- Keep components in good condition. Follow the maintenance procedures.
- Ensure the service area is clean, dry, and has sufficient lighting.
- Do not modify any components without written authorization from the manufacturer. Modification can be dangerous and result in serious injuries.
- Shut down and lock out power before maintaining equipment.
- After maintenance is complete, replace all guards, service doors, and/or covers.
- Use only genuine AGI replacement parts or equivalent. Use of unauthorized parts will void warranty. If in doubt, contact AGI or your local dealer.



Before attempting maintenance of any kind:

- Lower the auger fully.
- Chock wheels.
- Support tube if performing maintenance on the undercarriage assembly.
- **If equipped with hydraulics:** Before applying pressure to a hydraulic system, make sure all components are tight and that hoses and couplings are in good condition.

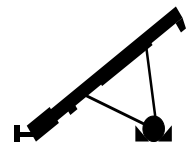

7.2. Maintenance Schedule

Proper maintenance habits mean a longer life, better efficiency, and safer operation. Please follow the Maintenance Schedule below. Keep good records of the hours the auger has been operated and the maintenance performed.

| |
|---|
| Daily: |
| Section 7.3 – Visually Inspect the Equipment on page 52 |
| Section 7.4 – Lubricate the Equipment on page 53 |
| Monthly: |
| Section 7.5 – Inspect Hydraulic Hoses and Fittings on page 55 |

| |
|---|
| Section 7.11 – Check the Gearbox Oil on page 58 |
| Annually: |
| Section 7.14 – Clean and Wash the Equipment on page 59 |
| 2–3 Years: |
| Section 7.8 – Service the Pulleys on page 56 |
| Section 7.9 – Service the Swing Tube Coupler Chain on page 57 |
| Section 7.10 – Service the Boot and Hopper Chain Drive on page 57 |
| Section 7.12 – Change the Gearbox Oil on page 59 |
| Section 7.13 – Service the Power Swing Drive Chain on page 59 |
| When equipped: Section 7.6 – Inspect and Service the Hand Winch and Lift Cable on page 55 |
| When equipped: Section 7.7 – Inspect and Service the Hydraulic Winch and Lift Cable on page 56 |
| As Required: |
| Section 7.15 – Removable Hopper Mesh Guard on page 60 |
| Section 7.16 – Repack the Wheel Bearings with Grease on page 60 |
| Section 7.17 – Check/Adjust the Truss Cables on page 61 |

7.3. Visually Inspect the Equipment

 **WARNING** Lock out power before inspecting.

Check the following during a visual inspection:

1. Ensure all guards are in place and in good working order.
2. Examine the auger for damage or unusual wear.
3. Check tightness of bolts/nuts, fasteners, and hardware (re-torque if necessary).
4. Be sure all safety decals are in place and are legible.
5. Check that the discharge and intake area are free of obstructions.
6. Inspect all moving or rotating parts to see if anything has become entangled in them. Remove any entangled material.
7. Inspect hydraulic hoses and fittings for leaks and wear. Fix or replace where necessary.
8. Check wheel bolts are tight and examine tires for gashes, uneven wear, or loss of air pressure. See [Section 9 – Specifications on page 65](#) for recommended tire pressure and torque information.
9. Check all operating, lifting, and transport components. Replace damaged or worn parts before using the auger.
10. Inspect the auger shaft bushing for unusual wear or discoloration.
11. Check the PTO shield & replace if damaged.
12. Inspect the winch cable for fraying, kinking, unwinding, or other possible damage.
13. Inspect the truss cables for proper tension and possible damage such as fraying, kinking, or unwinding.

7.4. Lubricate the Equipment

Your equipment can operate at top efficiency only if clean fluids and lubricants are used. Use clean containers to handle all fluids and lubricants. Store them in an area protected from dust, moisture, and other contaminants.

1. Wipe the grease fittings with a clean cloth before greasing to avoid injecting dirt and grit.
2. Use a hand-held grease gun for all greasing.
3. If fittings will not take grease, remove and clean thoroughly.
4. Replace fittings if they are broken or will not accept grease.
5. If Intake Bushing is present in your auger, lubricate it.

Use SAE multi-purpose high-temperature grease with extreme pressure (EP) performance. SAE multi-purpose lithium-based grease is also acceptable.

7.4.1 Grease Points

Apply grease to the locations shown in the following figures:

Figure 24. PTO Grease Fitting Locations

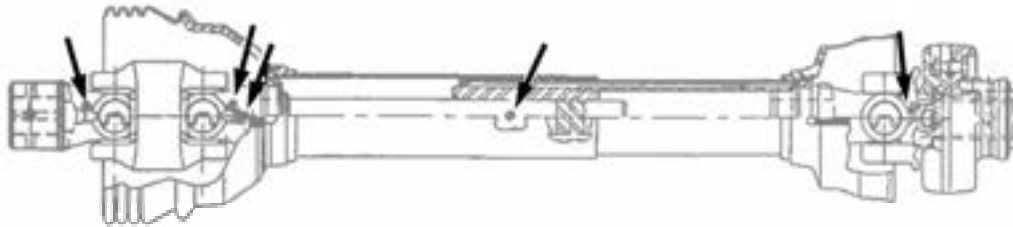

Figure 25. Hopper Grease Points

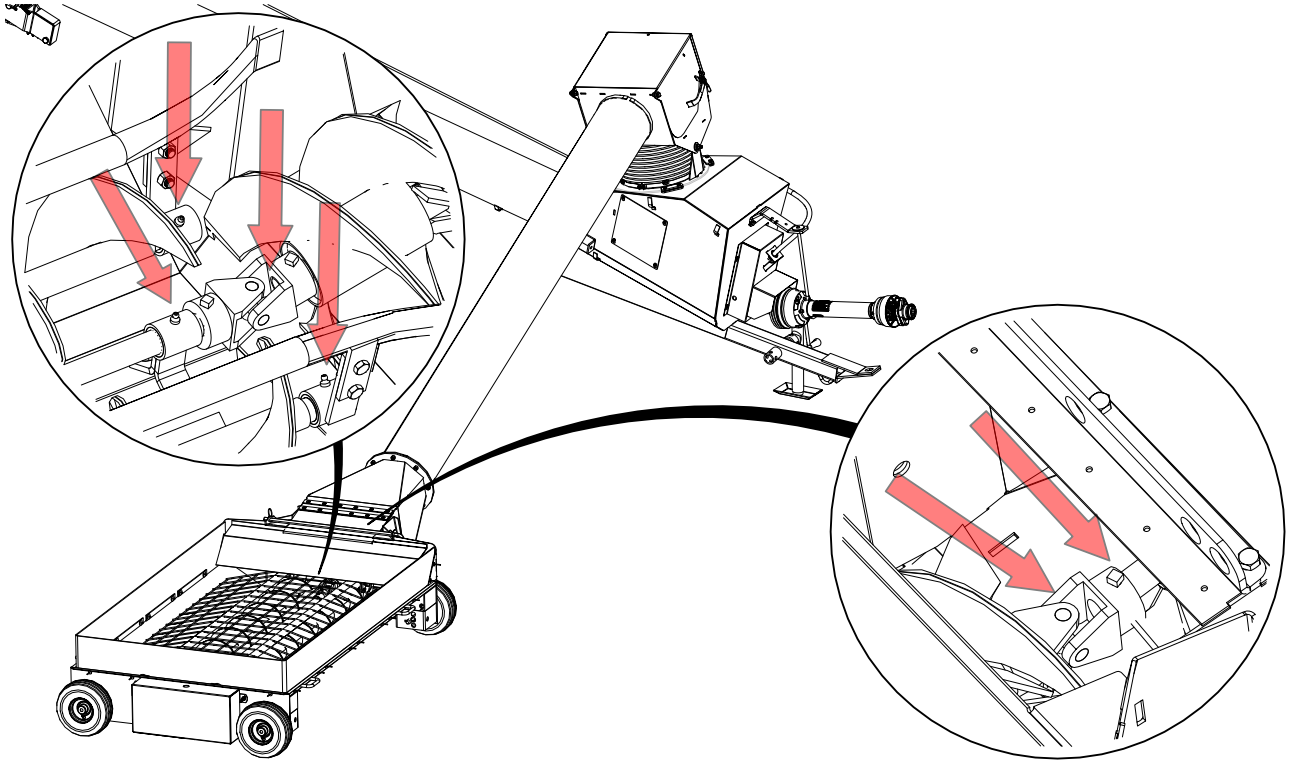

Figure 26. Upper Flighting Bearing Grease Point

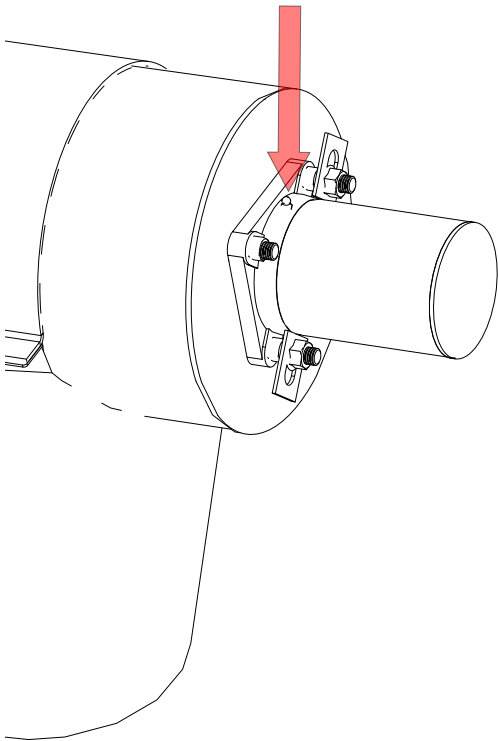
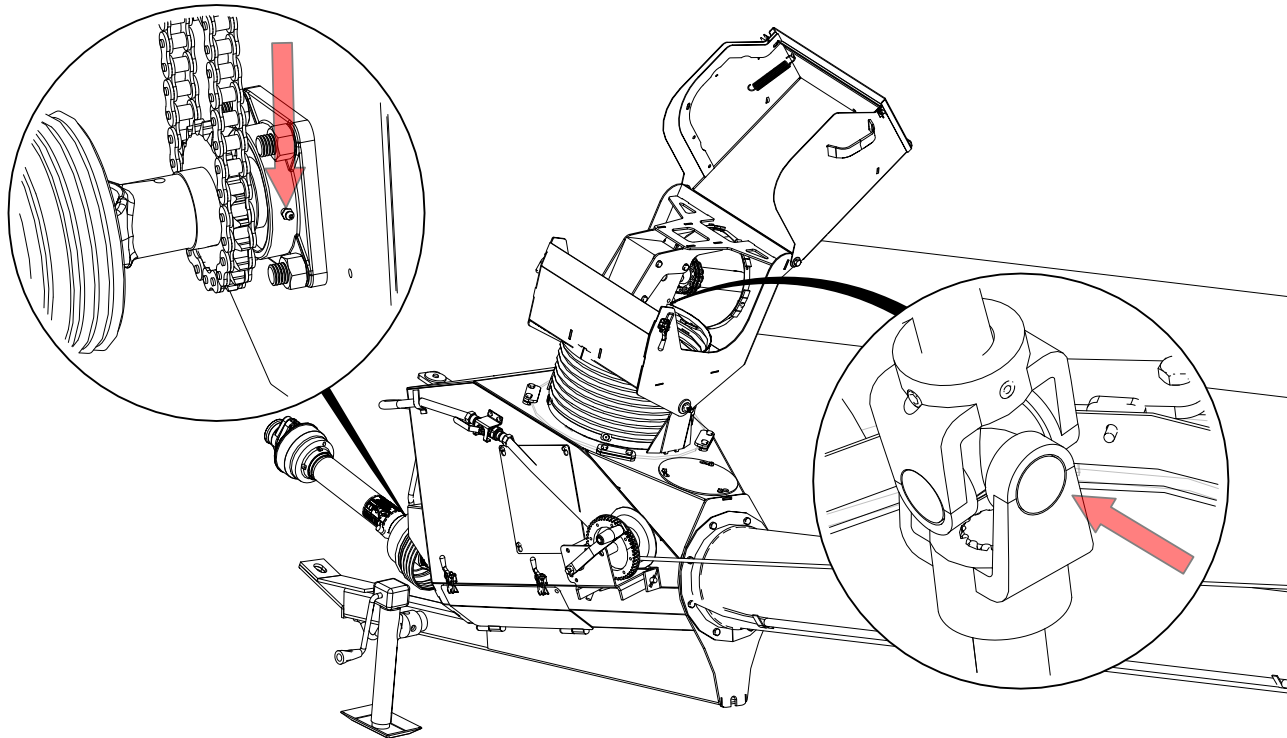

Figure 27. Boot Grease Points

7.5. Inspect Hydraulic Hoses and Fittings

➡ When equipped:

1. Pressurize the system.
2. Using a piece of cardboard or wood, run it along the length of the hose and around all fittings.

⚠ WARNING

 Escaping hydraulic fluid under pressure will cause serious injury if it penetrates the skin surface.
3. Replace the hose or tighten/replace the fitting if a leak is found. For replacement hoses, refer to [Section 9. – Specifications on page 65](#).
4. Replace any hose that is badly cut, nicked, abraded, or is separating from the crimped end of the fitting.
5. Secure hoses to the machine.

7.6. Inspect and Service the Hand Winch and Lift Cable

➡ When equipped:

⚠ WARNING Place auger in fully lowered position with cable slack.

1. Inspect the cable for damage such as fraying, kinking, or unwinding. Replace if damaged (see below).
2. Check to make sure cable clamps are secure.

3. Oil cable pulleys as needed.
4. Keep a film of grease on the gears. Occasionally oil the bushings, drum shaft, and ratchet.
5. Do not get oil or grease on brake discs.
6. Replace brake discs if less than 1/16" (1.6 mm) thick.
7. Check for proper ratchet pawl operation:
 - When cranking in (clockwise) = loud clicking
 - When cranking out (counterclockwise) = no clicking and ratchet pawl fully engaged into gear teeth.

To Replace the Lift Cable:

1. Unwind the winch drum until cable is slack and remove all cable clamps.
2. Free the cable from the winch and pulleys.
3. Remove the cable clamps that secure the hook in place.
4. Reverse the above steps to install the new cable.

7.7. Inspect and Service the Hydraulic Winch and Lift Cable

 **WARNING** Place the auger in the fully lowered position with the cable slack.

To Inspect the Lift Cable:

1. Inspect the cable for damage such as fraying, kinking, or unwinding. Replace if damaged (see below).
2. Check to make sure the cable clamps are secure.
3. Oil the cable pulleys as needed.
4. Keep a film of grease on the gears. Occasionally oil the bushings, drum shaft, and ratchet.

To Replace the Lift Cable:

1. Unwind the winch drum until the cable is slack and remove the cable clamps.
2. Free the cable from the winch and pulleys.
3. Remove the cable clamps that secure the hook in place.
4. Reverse the above steps to install the new cable.

7.8. Service the Pulleys

- Ensure the cable is slack before servicing the winch.
- Check to make sure cable clamps are secure.
- Keep a film of grease on the gears. Occasionally oil the bushings, drum shaft, and ratchet.
- Oil cable pulleys as needed.

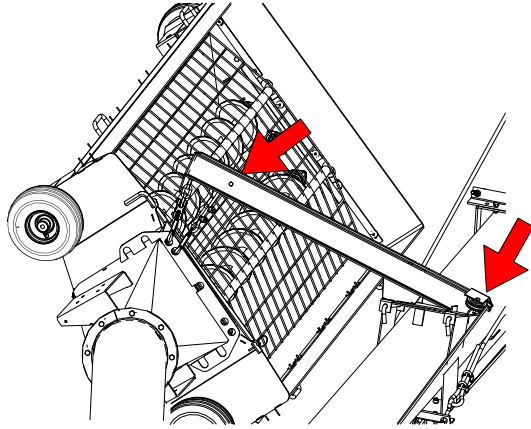
Figure 28. Cable Pulleys

7.9. Service the Swing Tube Coupler Chain

1. Remove any accumulated debris with a cloth or a soft wire brush.
2. Inspect the power transfer chain for wear.
3. Lightly oil the chain.

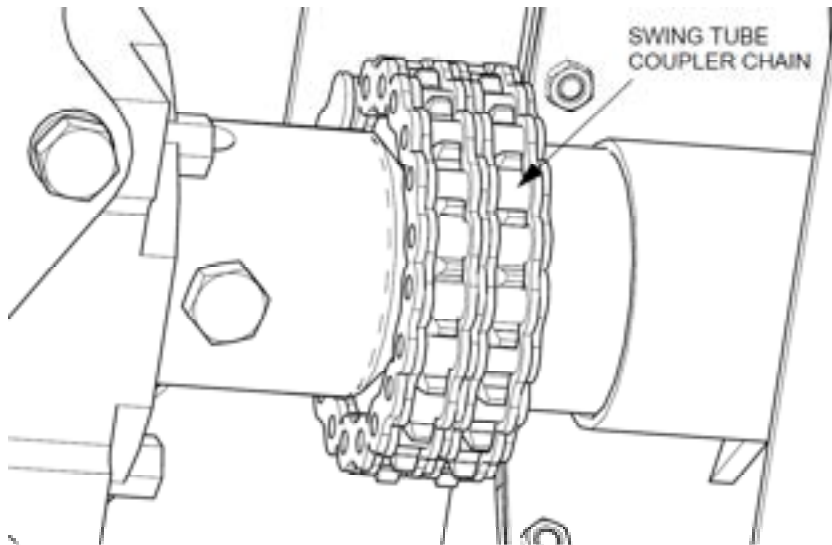
Figure 29. Swing Tube Coupler Chain

7.10. Service the Boot and Hopper Chain Drive

1. Remove chain cover plate from the boot or hopper.
2. Check the chain slack at the midpoint of the longest span. It should be no more than 1/4" (6 mm).

Note

The Hopper has two chains, one for each flighting.

3. Adjust the chain slack for the boot by loosening the 4 bolts of the lower bearing and adjust the chain slack [Figure 30](#).

Note

If the chain can't be tightened enough, remove a link from the chain. If the chain will not fit with one link removed, add a half link to the chain and replace.

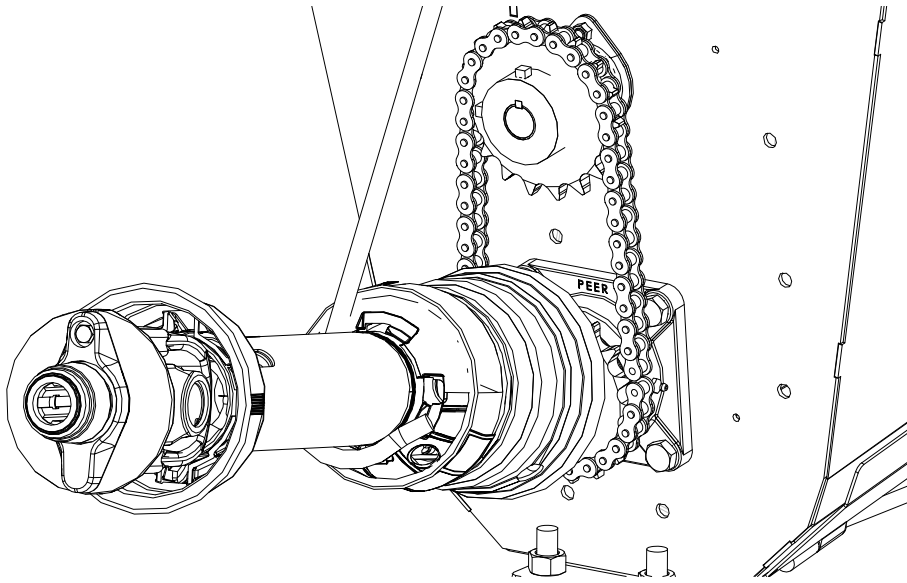
Figure 30. Boot Chain Drive

4. Tighten or loosen the adjustment nut on the side to set the chain slack for the hopper.

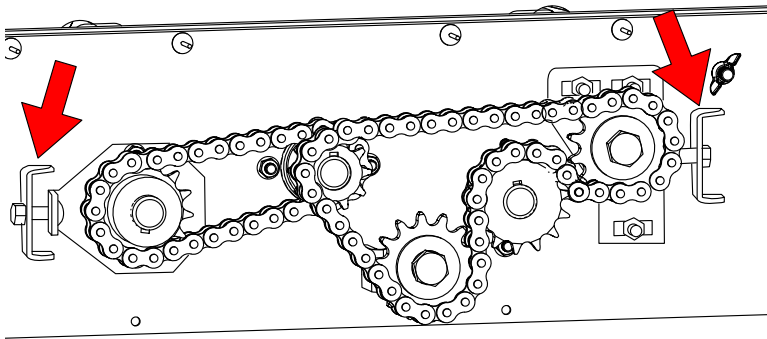
Figure 31. Hopper Chain Drive

5. Tighten the chain tension roller idler bolt to 120ft-lb using a torque wrench.

NOTICE

Improper adjustment of chain will result in premature wear.

6. Lightly oil the chain.

7.11. Check the Gearbox Oil

1. Remove fill/vent plug to check gearbox oil level. Insert an improvised dipstick (rolled paper or plastic tie) into the oil filler hole to determine the oil level.
2. Note the level and the condition of the oil. Maintain oil level at half full (center of cross shaft) with 90W or equivalent gear oil, adding as necessary or drain and refill if condition is poor.

3. Ensure gearbox is level when checking or refilling.
4. Do not overfill when adding oil.
5. Replace fill/vent plug.

7.11.1 Gearbox Access

Upper Gearbox: Unfasten latches, open spout-head lid, and service gearbox as required.

Lower Gearbox: Open square service door and service gearbox as required.

7.12. Change the Gearbox Oil

Use SAE approved 90W or equivalent gear oil.

1. Remove gearbox from the auger.
2. Place a pan under the drain plug.
3. Use a wrench and remove the drain plug.
4. Loosen the filler plug so air can enter the gearbox and the oil will drain freely.
5. Allow the oil to drain completely.
6. Replace the drain plug.
7. Add oil until the gearbox is half full (center of cross shaft) and replace filler plug. A flexible funnel may be required. Gearbox should be level when checking or refilling. **Do not overfill.**
8. Reinstall the gearbox and guards.

7.13. Service the Power Swing Drive Chain

1. Keep the drive chain tension adjusted to about 1/4" deflection by loosening the two bolts on the hydraulic or electric motor mount, then retighten. Apply the same procedure to the chain between the wheels. The tension for the inter-wheel drive chain is adjusted by loosening the two bolts on the wheel adjust plate; retighten when finished.
2. Oil chain frequently enough to keep a light film of oil on it.
3. Replace guards when complete.

7.14. Clean and Wash the Equipment

1. Clean out excess grain from all areas of the auger.
2. Make sure water can drain from the auger tube and intake, then wash the tube with a water hose or pressure washer until all dirt, mud, debris, or residue is gone.

Important

Do not contact electronic controls with high pressure washer.

3. Provide sufficient time for the water to drain from the auger.

7.15. Removable Hopper Mesh Guard

The hopper mesh guard can be removed for better access to clean out or to service the hopper components.

1. Remove the six hopper mesh straps securing the mesh guard to the hopper.
2. Remove the mesh guard.
3. Replace hopper mesh guard using the six existing mesh straps.



DANGER Re-install mesh before operating the auger. Serious injury or death could occur from an unguarded auger.

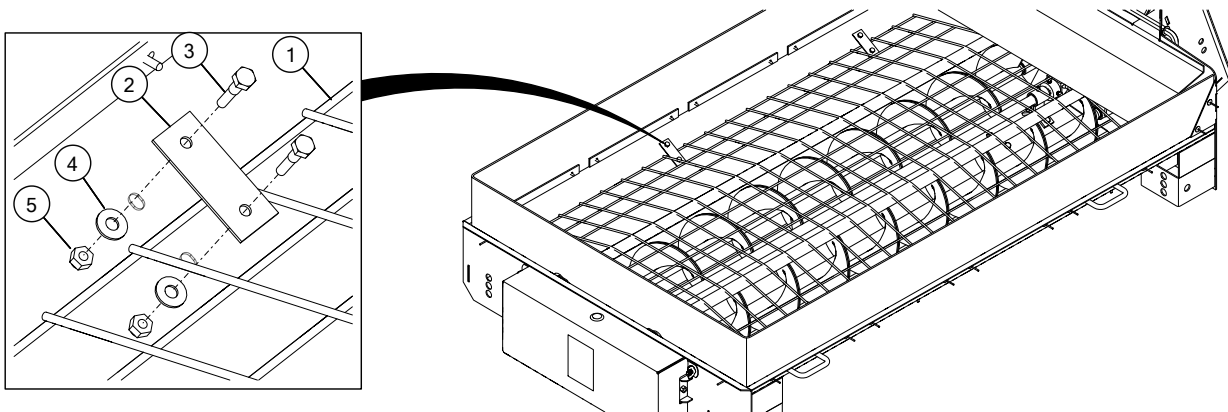

| | | | |
|---|---------------------|---|-------------------|
| 1 | Mesh Guard | 4 | Flat Washer, 1/4" |
| 2 | Mesh Strap | 5 | Locknut, 1/4" |
| 3 | Bolt, 1/4" x 1-1/4" | | |

7.16. Repack the Wheel Bearings with Grease

1. Block wheels and ensure unit is stable.
2. Remove the wheel bolts and the wheels.
3. Clean wheel and hub mounting surfaces to ensure there is no rust or debris.
4. Remove the wheel bearing and pack with grease. Use SAE multi-purpose high-temperature grease with extreme pressure (EP) performance. SAE multi-purpose lithium-based grease is also acceptable.
5. Tighten the wheel bolts (diagonal pattern) with a torque wrench to 80 ft-lb (± 10 ft-lb) of torque. Inspect to make sure the wheel is sitting flush with the hub.

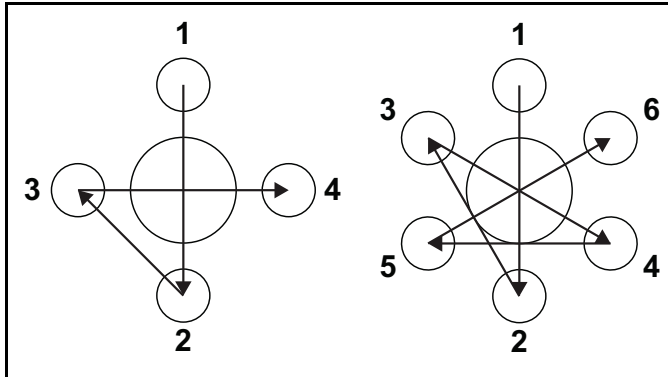
Figure 32. Diagonal Pattern for 4-bolt and 6-bolt Tires

7.17. Check/Adjust the Truss Cables

➡ When equipped with Truss Cables:

Check the Truss Cables:

Check tube for straightness, no slack in the cables, and a just noticeable upward deflection of the discharge end. During operation, it is normal that for the tube to deflect downward.

If required, adjust cables by following the procedure below:

1. Lift the discharge end of the auger with a overhead crane, front end loader, or other proper lifting device so that the tube has a slight upward deflection at the discharge to give the cable some slack.

CAUTION The lifting device must be capable of supporting approximately half of the weight of the auger as provided in the Specifications section.

- ➡ 2. When the auger has more than one set of cables start from the innermost cables and work your way out.
3. Loosen cable clamps on cable truss where the cable requires adjustment.
4. Locate the eyebolt anchors for the cable. Refer to [Figure 33 on page 62](#).
5. Tighten cable eyebolts evenly on both sides (use eyebolt nuts to tighten eyebolts) until the discharge end just starts to angle upward.
 - The tube should not deflect to the left or right if tightened evenly.
 - Tension should be greater on shorter cables than on longer cables. If the auger tubes remain straight then the cables are tensioned properly.
6. If the proper cable tension can't be obtained before the eyebolts run out of adjustment, then do the following:
 - a. Loosen the eyebolts.
 - b. At the eyebolts, loosen the cable clamps, shorten the cables until there is tension on the cable, then tighten the cable clamps fully.
 - c. Return to step 5.
7. Secure jam nut on cable eyebolt and re-tighten any cable clamps that were loosened.
8. The cables are properly tightened when:
 - There is no slack in the cables.

- The discharge end is deflected slightly upwards.
- The tube is straight side-to-side.

Table 4. Truss Cable Adjustment

| Item | Description |
|------|----------------------|
| 1 | Cable Clamp |
| 2 | Truss Cable |
| 3 | Cable Return Bracket |
| 4 | Cable Eyebolt |
| 5 | Eyebolt Nuts |
| 6 | Eyebolt Anchor |
| 7 | Cable Truss |

Figure 33. Typical Cable Truss Assembly

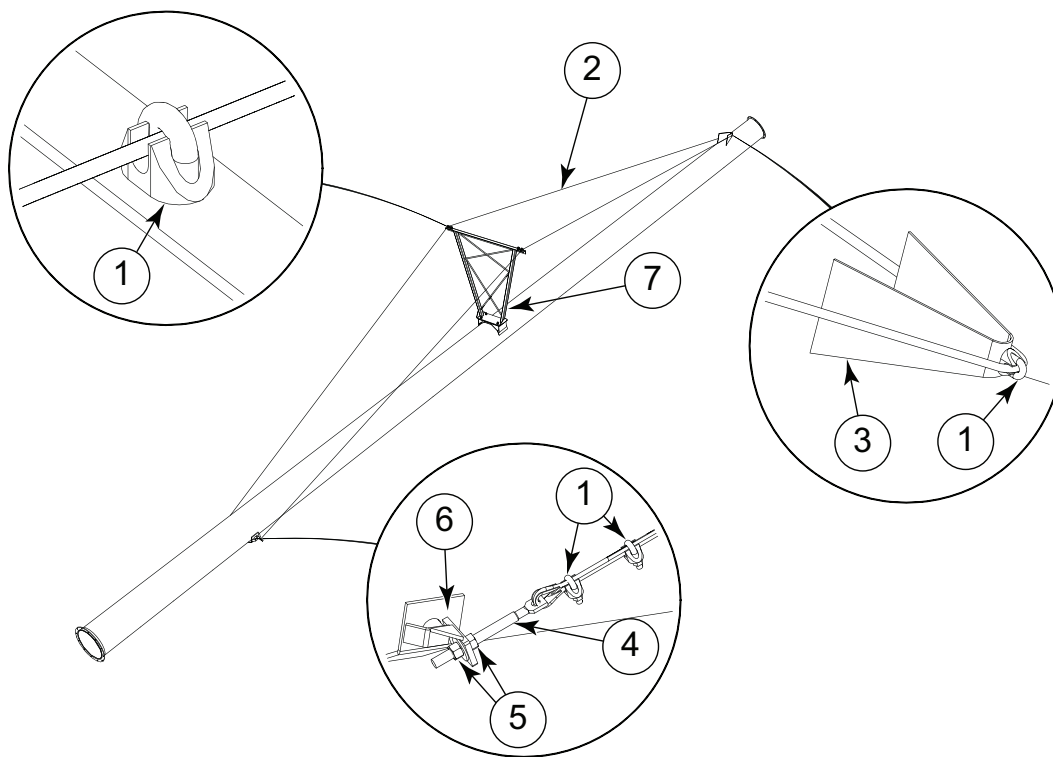

8. Troubleshooting



Before continuing, ensure you have completely read and understood this manual's Safety section, in addition to the safety information in the section(s) below.

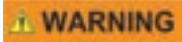

Shut down and lock out all power sources before diagnosing any of the causes or attempting any of the solutions below.

In the following section, we have listed some causes and solutions to some of the problems you may encounter.

If you encounter a problem that is difficult to solve, even after having read through this section, please contact your local dealer or distributor. Before you contact them, please have this operation manual and the serial number from your machine ready.

Auger

| Problem | Cause | Solution |
|------------------------------|---|---|
| Poor product flow. | Input speed is too slow. | Increase engine rpm. |
| | Inadequate material flow from truck or hopper. | Increase flow of material. |
| | Flow into the hopper is restricted. | Clear grating of obstructions. |
| | Material is too wet or heavy. | Unloading rates are for dry grain. |
| | Flighting is worn. | Repair or replace as required. |
| The flighting does not turn. | Auger flighting is plugged or obstructed. | Identify and remove obstruction. |
| | The coupler bolt below the non-rotating section is broken or missing. | Replace the bolt. |
| | Bearing is seized. | Identify the bearing and replace. |
| | A chain is broken. | Identify the chain and repair or replace. |
| | Gearbox is seized. | Fix or replace the gearbox. |
| | Gearbox coupler bolt is broken or missing. | Replace the bolt. |
| | A PTO shear bolt has failed. | Replace both PTO shear bolts. |

| | | |
|--|---|--|
| Auger flighting is noisy. | Obstruction in the auger tube. | Identify and remove obstruction. |
| | Flighting shaft bolts are loose or damaged. | Tighten or replace bolts. |
| | Flighting shaft is bent. | Repair or replace flighting shaft. |
| | Flighting is damaged. | Repair or replace flighting. |
| | Worn bearing. | Repair or replace bearing. |
| | Low gear oil level. | Inspect the gearbox, replace if damaged or add oil if not damaged. |
| Tube is misaligned. | Loose truss cables. | Tighten cables as required. |
| Excessive noise from hopper chain drive. | Loose chain. | Tighten chain drive, see Maintenance Section. |

Frame

| Problem | Cause | Solution |
|---|--|--|
| The auger will not raise or lower. | Closed hydraulic valve. | Open hydraulic valve. |
| | Inadequate hydraulic pressure. | Adjust the pressure if possible, or use an alternate hydraulic supply. |
| | Damaged cylinder. | Fix or replace the cylinder. |
| | Missing or broken cylinder pin. | Replace cylinder pin. |
| | Hydraulic system leak. | Identify and repair leak. |
| | Auger movement is obstructed. | Identify and clear the obstruction. |
| The auger will not stay in the elevated position. | Leak in auger hydraulic cylinder, fittings, or hose. | Lower auger to transport position and repair leaks as required. |
| | Leak in tractor hydraulics. | Close hydraulic valve to isolate cylinder from tractor hydraulics. |

9. Specifications

Table 5.

| Specification | | 10-63 | 10-73 | 10-83 |
|---|--------|--|---------------------|-------------------------------|
| CAPACITY | | | | |
| Unloading Rate | | 6600 Bu/Hr | | |
| DIMENSIONS | | | | |
| Tube Size | | 10" (25.4 cm) | | |
| Transport | Length | 64' 10" (19.76 m) | 75' (22.86 m) | 85' 1" (25.93 m) |
| | Width | 132" (3.35 m) | 132" (3.35 m) | 132" - 180" (3.35 m - 4.57 m) |
| | Height | 13' 8" (4.16 m) | 13' 4" (4.06 m) | 13' 4" (4.06 m) |
| Discharge Clearance | Min | 12' (3.66 m) | 11' 2" (3.4 m) | 11' 8" (3.56 m) |
| | Max | 43' 7" (13.28 m) | 47' 10" (14.58 m) | 55' 3" (16.84 m) |
| Reach to Wheels | Min | 23' 4" (7.11 m) | 27' 9" (8.46 m) | 29' 10" (9.09 m) |
| | Max | 31' 4" (9.55 m) | 35' 3" (10.74 m) | 40' 11" (12.47 m) |
| TIRES | | | | |
| Type | | 16" TRF | | |
| Inflation Pressure | | See Manufacturer Recommended Pressure on Tire Sidewall | | |
| Hubs | | 6-Bolt Automotive type | | |
| WEIGHT | | | | |
| Total Weight | | 3,475 lb (1 576 kg) | 3,790 lb (1 719 kg) | 4,362 lb (1 979 kg) |
| PTO DRIVE | | | | |
| Power Requirements | | 60 HP | 65 HP | 75 HP |
| PTO Speed | | 540 RPM | | |
| PTO Shaft | | 14R | | 35R |
| PTO Maximum Operating Angle | | 15° | | |
| OTHER | | | | |
| Hitch Jack | | 2000 lb (side wind) | | |
| Hitch Pin Size (Minimum) | | 3/4" x 5" | | |
| Upper/Lower Gear Box Oil Capacity | | 0.45 US quarts (0.43 L) | | |
| Minimum Pressure Capacity of Hydraulic Hose & Hose Ends | | 2500 psi (17200 kPa) | | |
| Pressure Required to Raise Auger | | 1200 PSI (8274 kPa) | 1400 PSI (9653 kPa) | 1600 PSI (11032 kPa) |
| Shear Bolt Size | | 5/16" x 1" | | |

10. Appendix

10.1. Power Swing Remote Transmitter Instructions

Figure 34 shows the controls and indicators for the power swing remote and receiver.

Figure 34. Remote Transmitter and Receiver Controls and Indicators

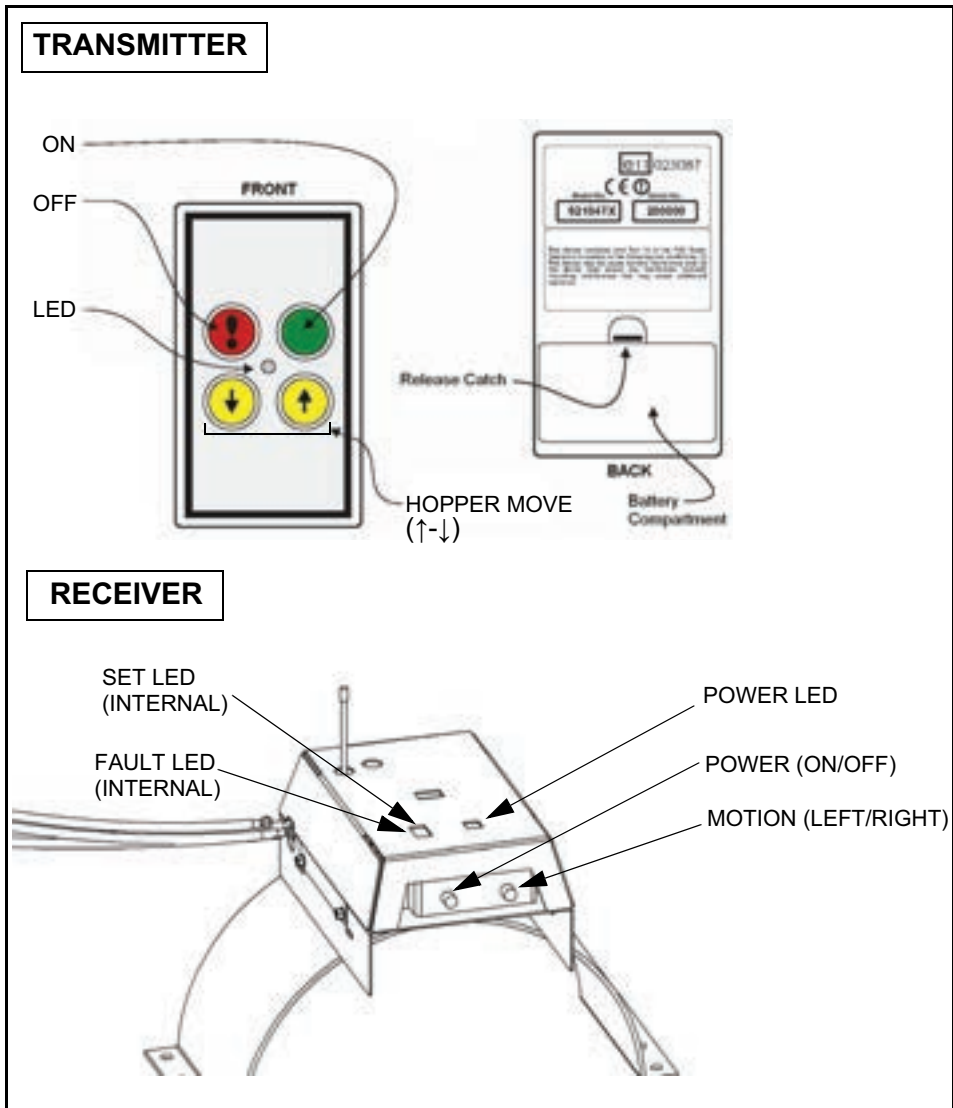

Important

The transmitter LED blinks on and off when the transmitter and receiver are active (turned on by the transmitter) and no other button is pressed. The LED turns fully on while a transmitter button is pressed, unless the transmitter battery is low, in which case the LED pulses on and off.

NOTICE

The transmitter automatically transmits a **STOP** signal after 30 minutes; this de-activates the receiver and the transmitter keypad.

NOTICE

The remote transmitter that comes with each power swing is normally factory programmed to function with the power swing receiver. Refer to specific instructions for programming additional or replacement remotes according to the serial number of the power swing receiver.

10.2. Programming Receivers

Turn on all the remote transmitters before programming.

Note

To de-register all remote transmitters from the receiver, hold down the OFF button on a remote for at least 60 seconds.

TO REGISTER THE FIRST REMOTE TRANSMITTER:

1. Switch OFF the receiver.

Important

Steps 2 and 3 must be done within 10 seconds of each other. The FAULT LED on the receiver flashes for the duration of the registration window.

2. Switch ON the receiver.
3. On the first remote, press the ON button and the yellow Down-Arrow Motion button at the same time and hold until the red light on the receiver SET LED illuminates solid red. Release buttons. The remote is programmed, and should be set aside.

TO REGISTER A SECOND REMOTE TRANSMITTER:

1. Switch OFF the receiver.

Important

Steps 2 and 3 must be done within 10 seconds of each other. The FAULT LED on the receiver flashes for the duration of the registration window.

2. Switch ON the receiver.
3. On a 2nd remote, press and release the ON button once, then press the ON button and the Down-Arrow Motion button at the same time and hold until the red light on the receiver SET LED illuminates solid red. Release buttons. The remote is programmed, and should be set aside.

TO REGISTER A THIRD REMOTE TRANSMITTER:

1. Switch OFF the receiver.

Important

Steps 2 and 3 must be done within 10 seconds of each other. The FAULT LED on the receiver flashes for the duration of the registration window.

2. Switch ON the receiver.
3. On a 3rd remote, press and release the ON button twice, then press the ON button and the Down-Arrow Motion button at the same time and hold until the red light on the receiver SET LED illuminates solid red. Release buttons. The remote is programmed, and should be set aside.

TO REGISTER A FOURTH REMOTE TRANSMITTER:

1. Switch OFF the receiver.

Important

Steps 2 and 3 must be done within 10 seconds of each other. The FAULT LED on the receiver flashes for the duration of the registration window.

2. Switch ON the receiver.
3. On a 4th remote, press and release the ON button three times, then press the ON button and the Down-Arrow Motion button at the same time and hold until the red light on the receiver SET LED illuminates solid red. Release buttons. The remote is programmed, and should be set aside.

10.3. How to Charge the Lift System

Important

The hydraulic cylinders are shipped without oil and must be charged with oil before auger is put into operation.

The cylinder will require about 19 L (5 US gallons). Check your tractor's operation manual for correct oil type and specifications.

Before charging cylinders, ensure that:

- Tractor is correctly hooked up.
- Hydraulic hoses are connected.
- Shut-off valve is open.
- Auger is parked on level ground.

Note

Do not raise auger in high winds.

1. Start with the tractor's hydraulic oil level in a normal operating range.
2. Add about 4 L (1 US gallon) to the tractor's hydraulic oil reservoir.
3. Start tractor, then raise auger until the lift-assist is fully extended and track shoe has moved about 1' from trackstop.
4. **With tractor still running**, lower auger to full down position.
5. Repeat steps 2, 3, and 4 until about 19 L (5 US gallons) have been added and tractor hydraulic oil level in the reservoir remains within the operating range.

10.4. Open/Closed-Center Valve Conversion

Note

The standard configuration for the control valve is closed-center. The closed-center plug is pre-installed when delivered from AGI.

The control valve can be converted from the closed-center to the open-center configuration by removing the conversion plug.

- Remove outlet plug to access the closed-center plug.
- Remove the closed-center conversion plug for open-center operation.
- Re-install outlet plug.

Note

Retain the conversion plug that was removed for future use.

Figure 35. Conversion Plug Location

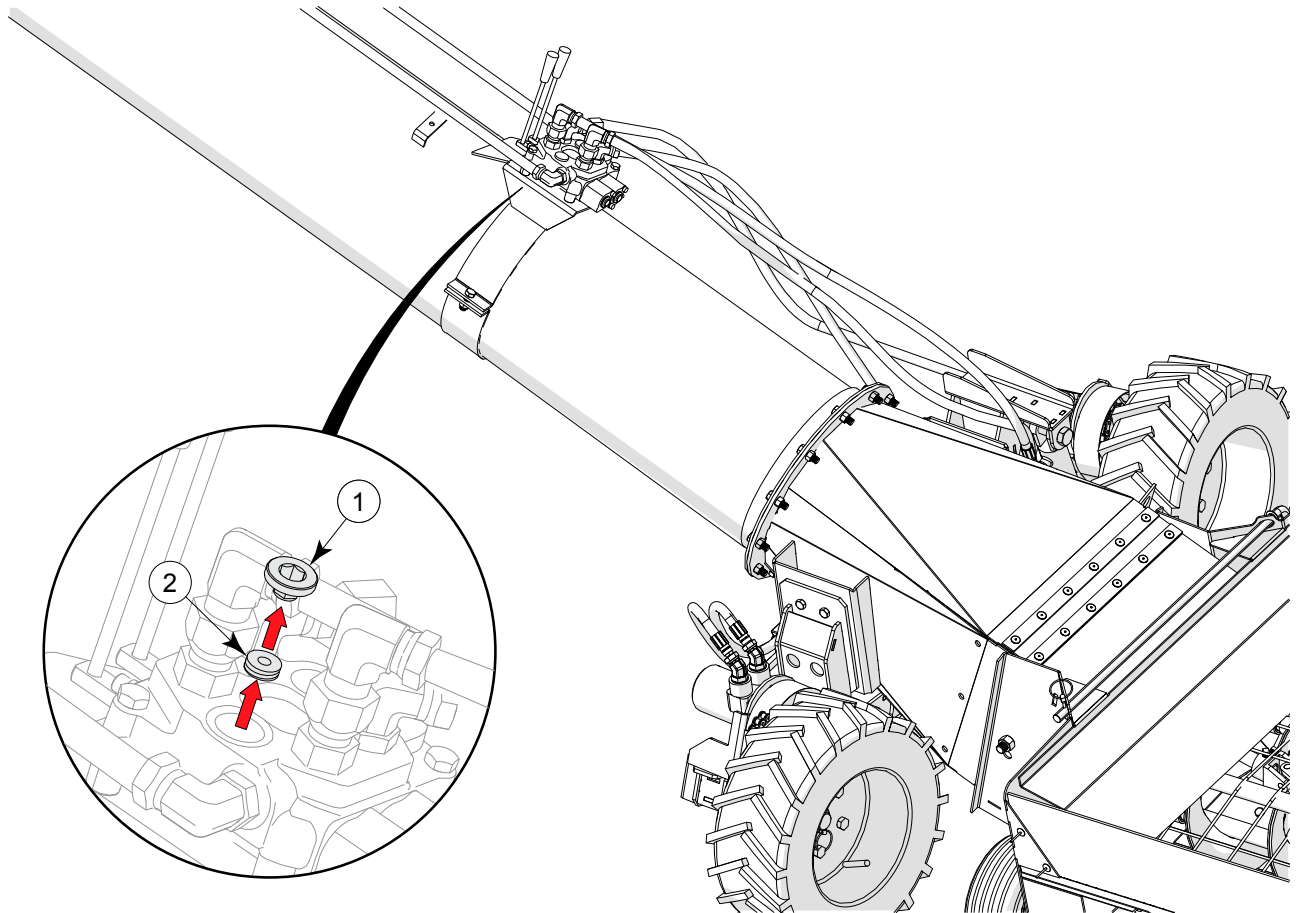

| Item | Description |
|------|--------------------|
| 1 | Outlet Plug |
| 2 | Closed-Center Plug |

11. AGI Limited Warranty

This warranty relates to AGI Augers (the “Product”) sold by AGI, (referred to herein as the “Seller”) and applies only to the first user of the Product (meaning a purchaser directly from the Seller or from an authorized dealer or distributor of the Product, referred to herein as the “Buyer”).

This warranty shall only be effective if properly registered with the Seller in accordance with information provided to the Buyer at the time of sale.

1. The Seller warrants to the Buyer that the Product is free from defects in material and workmanship **under normal and reasonable use.**
2. This warranty applies only to defects in materials and workmanship and not to damage incurred in shipping or handling, through normal wear and tear, or damage due to causes beyond the control of the Seller such as lightning, fire, flood, wind, earthquake, excessive voltage, mechanical shock, water damage, or damage arising out of abuse, alteration, improper assembly, improper installation, improper maintenance or improper repair of the Product.
3. **The warranty period for the Product shall be two years from delivery of the Product to the Buyer where the Product is used in a normal farm operation. First year of warranty coverage of parts and labour, second year warranty coverage of parts only. Warranty period for the Product shall be 90 days from delivery of the Product to the Buyer where the Product is used in a commercial operation.** In the event that any part incorporated into the Product is manufactured and sold to the Seller by a third party vendor, such part is only warranted to the extent of the warranty given by that third party.
4. The obligations set forth in this warranty are conditional upon the Buyer promptly notifying the Seller of any defect and completing reasonably required documentation and, if required, promptly making the Product available for correction. The Seller shall be given reasonable opportunity to investigate all claims and no Product shall be returned to the Seller or part disposed of until after inspection and approval by the Seller and receipt by the Buyer of written shipping instructions, with transportation charges prepaid.
5. Upon return of the Product, or such part of the Product that requires correction, the Seller shall, at the Seller’s option, either repair or replace the Product or such part. The Seller shall replace or attempt to repair and return the Product or such part within a reasonable period of time from receipt of an approved warranty claim from the Buyer. If the Seller is unable to repair or replace the Product, the Buyer shall be entitled to a credit note in the amount of the purchase price for the Product.
6. The total liability of the Seller on any claim, whether in contract, tort or otherwise, arising out of, connected with, or resulting from the manufacture, sale, delivery, repair, replacement or use of the Product or any part thereof **shall not exceed the price paid for the Product** and the Seller shall not be liable for any special indirect, incidental or consequential damages caused by reason of the installation, modification, use, repair, maintenance or mechanical failure of the Product. **Consequential or special damages as used herein include, but are not limited to, lost or damaged products or goods, costs of transportation, lost sales, lost orders, lost income, increased overhead, labor and incidental costs and operational inefficiencies.**
7. **Notwithstanding anything contained herein to the contrary, the foregoing is the Buyer’s sole and exclusive remedy for breach of warranty by the Seller in respect of the Product. The Seller, for itself, its agents, contractors, employees and for any parent or subsidiary of the Seller, expressly disclaims all warranties, either express or implied, written or oral, including implied warranties of merchantability or fitness for a particular purpose and undertakes no obligation with respect to the conformity of the Product except as set out in the purchase agreement, if any, or marketing materials.**
8. The foregoing warranty is the entire warranty of the Seller to the Buyer and the Buyer shall not be entitled to rely upon any representation or warranty contained in any marketing material of the Seller in respect of the Product. The Seller neither assumes, nor authorizes any other person purporting to act on its behalf to modify or to change this warranty, nor to assume for it any other warranty or liability concerning the Product.

WARRANTY VOID IF NOT REGISTERED



P.O. Box 39
Rosenort, Manitoba, R0G 1W0 Canada
Phone: (866) 467-7207 (Canada & USA) or (204) 746-2396
Fax: (866) 768-4852

Website: www.aggrowth.com
Email: sales@grainaugers.com
©Ag Growth International Inc. 2020
Printed in Canada

If you have any comments or questions on this manual, or find an error, email us at comments@aggrowth.com.
Please include the part number listed on the cover page in your message.