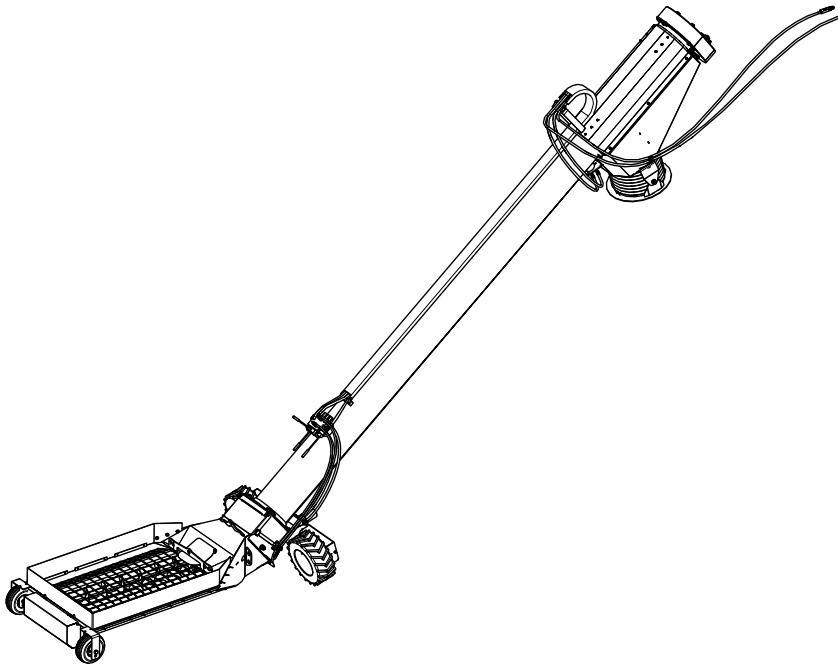




# MKX-Tend Hopper

## MKX130 Operator and Assembly Manual

Original Instructions



Read this manual before using product. Failure to follow instructions and safety precautions can result in serious injury, death, or property damage. Keep manual for future reference.

Part Number: 31020 R0

Revised: May 2017





# CONTENTS

- 1. Introduction ..... 5**
  - 1.1. Serial Number Location ..... 5
- 2. Safety ..... 6**
  - 2.1. Safety Alert Symbol and Signal Words ..... 6
  - 2.2. General Safety ..... 6
  - 2.3. Additional Safety Information ..... 7
  - 2.4. Rotating Flighting Safety ..... 7
  - 2.5. Rotating Parts Safety ..... 7
  - 2.6. Guards Safety ..... 7
  - 2.7. Hydraulic Winch Safety ..... 8
  - 2.8. Work Area Safety ..... 8
  - 2.9. Drives and Lockout Safety ..... 10
    - 2.9.1 Hydraulic Power Safety ..... 10
  - 2.10. Personal Protective Equipment ..... 11
  - 2.11. Safety Equipment ..... 11
  - 2.12. Safety Decals ..... 13
    - 2.12.1 Decal Installation/Replacement ..... 13
    - 2.12.2 Safety Decal Locations and Details ..... 13
- 3. Features ..... 19**
- 4. Assembly ..... 20**
  - 4.1. Assembly Safety ..... 20
  - 4.2. General Assembly ..... 20
  - 4.3. Verify Auger Assembly ..... 21
    - 4.3.1 Install the MKX-Tend Hopper Lift Arm ..... 21
    - 4.3.2 Replace the Short Truss Brace ..... 22
    - 4.3.3 Install the Hydraulic Winch ..... 23
- 5. Operation ..... 26**
  - 5.1. Operation Safety ..... 26
  - 5.2. Transport Preparation ..... 26
  - 5.3. Operator Controls ..... 28
  - 5.4. Start-Up and Break-In ..... 29
    - 5.4.1 Prior to First Use ..... 29
    - 5.4.2 After First Use ..... 30
  - 5.5. MKX-Tend Hopper Operation ..... 30
- 6. Maintenance ..... 32**
  - 6.1. Maintenance Safety ..... 32
  - 6.2. Lubricate the Equipment ..... 32
  - 6.3. Service Interval ..... 33
    - 6.3.1 Weekly Service ..... 33
    - 6.3.2 Semi-Annual Service ..... 34
    - 6.3.3 Annual Service ..... 35
  - 6.4. Adjusting the Hopper Drive Chain Tension ..... 35
  - 6.5. Adjusting the Wheel Drive Chain Tension ..... 37
  - 6.6. Swing Auger Chain Tension ..... 38
- 7. Troubleshooting ..... 39**

**8. Specifications ..... 40**

**9. Appendix ..... 41**

    9.1. Tightening O-Ring Fittings ..... 41

    9.2. Bolt Torque Values ..... 41

**10. Westfield Auger Warranty ..... 44**

# 1. Introduction

Thank you for purchasing a Westfield MKX-Tend Hopper. This equipment will allow safe and efficient operation when you read and follow all of the instructions contained in this manual. With proper care, your MKX-Tend hopper will provide you with many years of trouble-free operation.

Keep this manual handy for frequent reference and to review with new personnel. A sign-off form is provided on the inside front cover for your convenience. If any information in this manual is not understood or if you need additional information, please contact your local distributor or dealer for assistance.

This manual should be regarded as part of the equipment. Suppliers of both new and second-hand equipment are advised to retain documentary evidence that this manual was provided with the equipment.

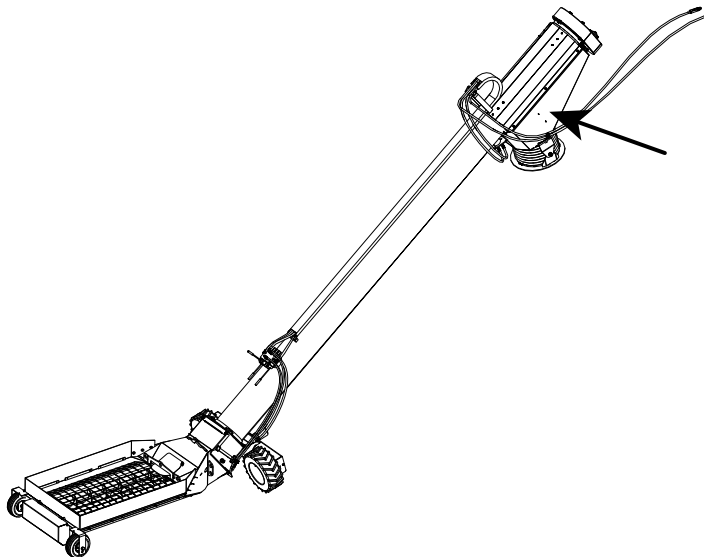
This manual describes the assembly and operation of the MKX-Tend hopper, used as an accessory on MKX130 grain augers, and is intended as a supplement to your MKX130 Series Auger Operator Manual. Refer to the appropriate manual for additional operating and maintenance instructions.

## 1.1. Serial Number Location

Always give your dealer the serial number on your MKX-Tend hopper (shown below) when ordering parts or requesting service or other information. Please record this information in the table below for easy reference.

<b>Model Number</b>	
<b>Serial Number</b>	
<b>Date Received</b>	

Figure 1. Serial Number Location



# 2. Safety


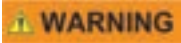


## 2.1. Safety Alert Symbol and Signal Words

---



This safety alert symbol indicates important safety messages in this manual. When you see this symbol, be alert to the possibility of injury or death, carefully read the message that follows, and inform others.

**Signal Words:** Note the use of the signal words **DANGER**, **WARNING**, **CAUTION**, and **NOTICE** with the safety messages. The appropriate signal word for each message has been selected using the definitions below as a guideline.

-  **DANGER** Indicates an imminently hazardous situation that, if not avoided, will result in serious injury or death.
-  **WARNING** Indicates a hazardous situation that, if not avoided, could result in serious injury or death.
-  **CAUTION** Indicates a hazardous situation that, if not avoided, may result in minor or moderate injury.
-  **NOTICE** Indicates a potentially hazardous situation that, if not avoided, may result in property damage.

## 2.2. General Safety

---

The safety information in the safety section of this manual applies to all safety practices. Specific safety information (such as Operation Safety), can be found in the appropriate section.

**YOU** are responsible for the **SAFE** use and maintenance of your MKX-Tend hopper. **YOU** must ensure that you and anyone else who is going to work around the MKX-Tend hopper understands all procedures and related **SAFETY** information contained in this manual.

Remember, **YOU** are the key to safety. Good safety practices not only protect you, but also the people around you. Make these practices a working part of your safety program. All accidents can be avoided.

- It is the MKX-Tend hopper owner, operator, and maintenance personnel's responsibility to read and understand **ALL** safety instructions, safety decals, and manuals and follow them when assembling, operating, or maintaining the equipment.
- Owners must give instructions and review the information initially and annually with all personnel before allowing them to operate the MKX-Tend hopper. Untrained users/operators expose themselves and bystanders to possible serious injury or death.
- The MKX-Tend hopper is not intended to be used by children.
- Use the MKX-Tend hopper for its intended purposes only.
- Do not modify the MKX-Tend hopper in any way without written permission from the manufacturer. Unauthorized modification may impair the function and/or safety, and could affect the life of the MKX-Tend hopper. Any unauthorized modification of the MKX-Tend hopper will void the warranty.



## 2.3. Additional Safety Information

---



This manual is a supplement to the Series Operator Manual. Please ensure that you have read and understood that manual.

## 2.4. Rotating Flighting Safety

---

### DANGER

- KEEP AWAY from rotating flighting.
- DO NOT remove or modify flighting guards, doors, or covers. Keep in good working order. Have replaced if damaged.
- DO NOT operate the MKX-Tend hopper without all guards, doors, and covers in place.
- NEVER touch the flighting. Use a stick or other tool to remove an obstruction or clean out.
- Shut off and lock out power to adjust, service, or clean.



## 2.5. Rotating Parts Safety

---

### WARNING

- Keep body, hair, and clothing away from rotating pulleys, belts, chains, and sprockets.
- Do not operate with any guard removed or modified. Keep guards in good working order.
- Shut off and remove key or lock out power source before inspecting or servicing machine.



## 2.6. Guards Safety

---

### WARNING

- Keep guards in place and do not operate unless all guards are in place.
- Do not walk on, step on, or damage guards.
- Lock out power before removing a guard.
- Ensure all guards are replaced after performing maintenance.

## 2.7. Hydraulic Winch Safety

---

### **WARNING** When Equipped:

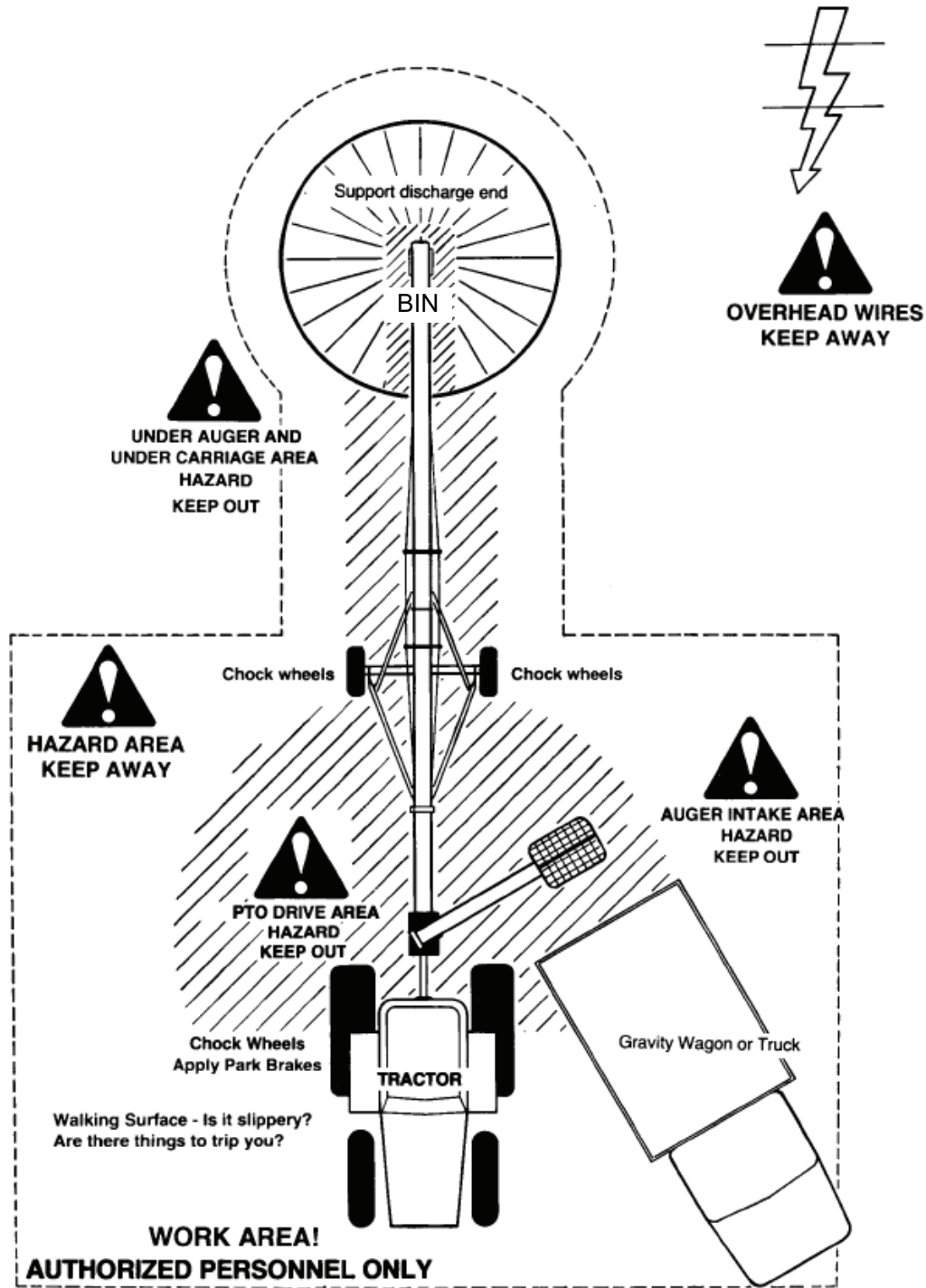
- Keep away from rotating cable drum and winch cable. Do not touch or grab cable while winch is being operated or use hands to guide the cable. Failure to heed could result in serious injury.
- Inspect cable and cable clamps before installing and using hydraulic winch. Replace cable if frayed or damaged. Tighten cable clamps if necessary.
- Do not continue to supply power to hydraulic winch after the MKX-Tend hopper has reached full up position.
- Do not disconnect hydraulic quick couplers when lines are pressurized.
- Make sure lift cable is seated in cable pulley.
- Always keep a minimum of 3 cable wraps on the cable drum.

## 2.8. Work Area Safety

---

- ### **WARNING**
- Have another trained person nearby who can shut down the MKX-Tend hopper in case of accident.
  - The work area should be kept clear of bystanders.
  - Keep the work area clean and free of debris.





## 2.9. Drives and Lockout Safety

Inspect the power source(s) before using and know how to shut down in an emergency. Whenever you service or adjust your equipment, make sure you shut down your power source and follow lockout and tagout procedures to prevent inadvertent start-up and hazardous energy release. Know the procedure(s) that applies to your equipment from the following power source(s).



For example:

- De-energize, block, and dissipate all sources of hazardous energy.
- Lock out and tag out all forms of hazardous energy.
- Ensure that only 1 key exists for each assigned lock, and that you are the only one that holds that key.
- After verifying all energy sources are de-energized, service or maintenance may be performed.
- Ensure that all personnel are clear before turning on power to equipment.

For more information on occupational safety practices, contact your local health and safety organization.

### 2.9.1 Hydraulic Power Safety

#### **WARNING** Power Source

- Refer to the rules and regulations applicable to the power source operating your hydraulic drive.
- Do not connect or disconnect hydraulic lines while system is under pressure.
- Keep all hydraulic lines away from moving parts.
- Escaping hydraulic fluid under pressure will cause serious injury if it penetrates the skin surface (serious infection or toxic reaction can develop). See a doctor immediately if injured.
- Use metal or wood as a backstop when searching for hydraulic leaks and wear proper hand and eye protection.
- Check all hydraulic components are tight and in good condition. Replace any worn, cut, abraded, flattened, or crimped hoses.
- Clean the connections before connecting to equipment.
- Do not attempt any makeshift repairs to the hydraulic fittings or hoses with tape, clamps, or adhesive. The hydraulic system operates under extremely high pressure; such repairs will fail suddenly and create a hazardous and unsafe condition.



#### **Lockout**

- Always place all hydraulic controls in neutral and relieve system pressure before disconnecting or working on hydraulic system.

## 2.10. Personal Protective Equipment

---

The following Personal Protective Equipment (PPE) should be worn when operating or maintaining the equipment.

### Work Gloves

- Wear work gloves to protect your hands from sharp and rough edges.



### Steel-Toe Boots

- Wear steel-toe boots to protect feet from falling debris.



### Safety Glasses

- Wear safety glasses at all times to protect eyes from debris.



### Dust Mask

- Wear a dust mask to prevent breathing potentially harmful dust.



### Hard Hat

- Wear a hard hat to help protect your head.



### Coveralls

- Wear coveralls to protect skin.



## 2.11. Safety Equipment

---

The following safety equipment should be kept on site:

### Fire Extinguisher

- Provide a fire extinguisher for use in case of an accident. Store in a highly visible and accessible place.



**First-Aid Kit**

- Have a properly-stocked first-aid kit available for use should the need arise, and know how to use it.



## 2.12. Safety Decals

---

- Keep safety decals clean and legible at all times.
- Replace safety decals that are missing or have become illegible. See decal location figures that follow.
- Replaced parts must display the same decal(s) as the original part.
- Replacement safety decals are available **free of charge** from your distributor, dealer, or factory.

### 2.12.1 Decal Installation/Replacement

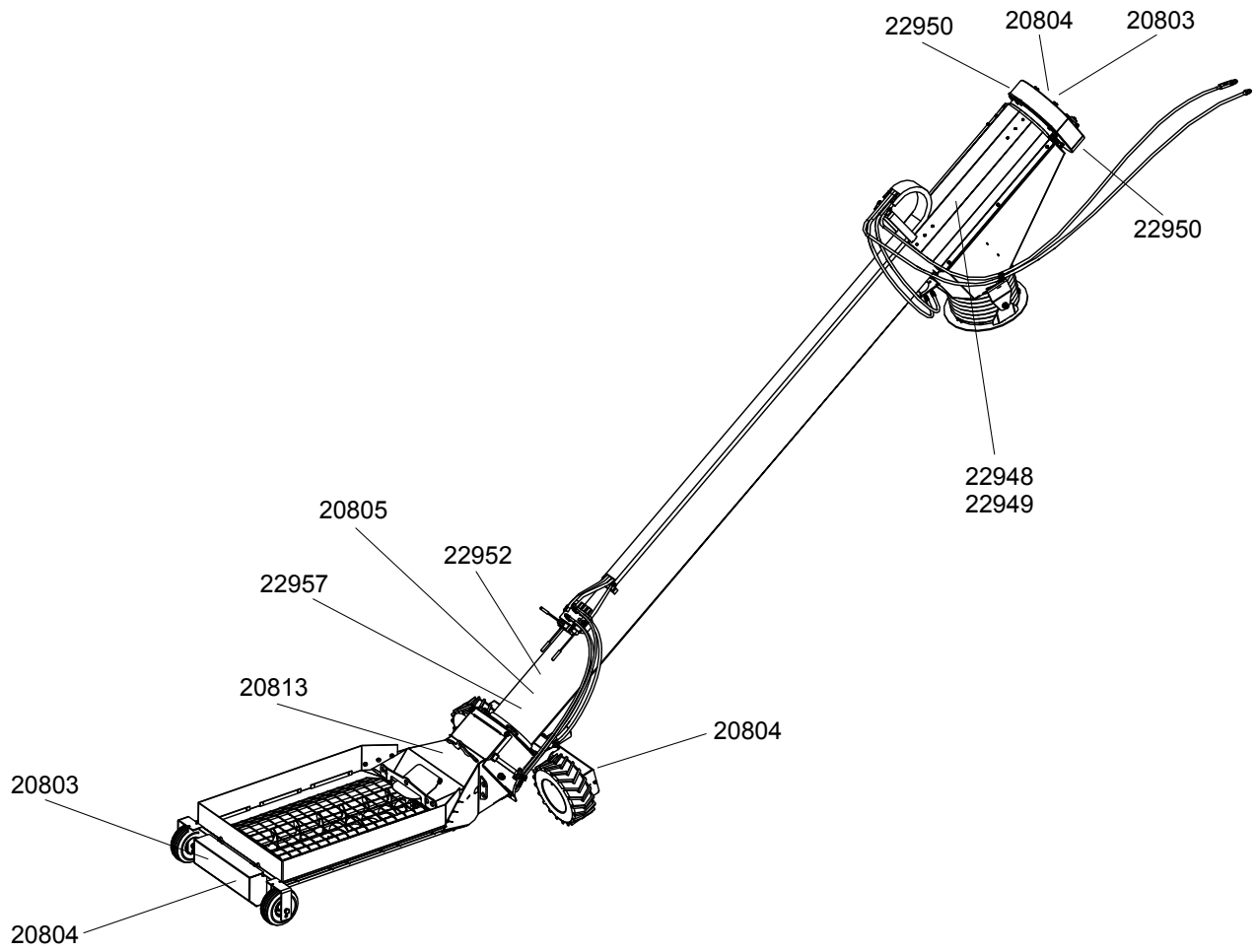
1. Decal area must be clean and dry, with a temperature above 50°F (10°C).
2. Decide on the exact position before you remove the backing paper.
3. Align the decal over the specified area and carefully press the small portion with the exposed sticky backing in place.
4. Slowly peel back the remaining paper and carefully smooth the remaining portion of the decal in place.
5. Small air pockets can be pierced with a pin and smoothed out using the sign backing paper.

### 2.12.2 Safety Decal Locations and Details



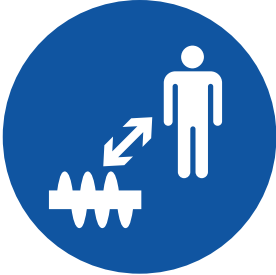



Replicas of the safety decals that are attached to the MKX-Tend hopper and their messages are shown in the figure(s) that follow. Safe operation and use of the MKX-Tend hopper requires that you familiarize yourself with the various safety decals and the areas or particular functions that the decals apply to, as well as the safety precautions that must be taken to avoid serious injury, death, or damage.



Figure 2. Safety Decal Locations



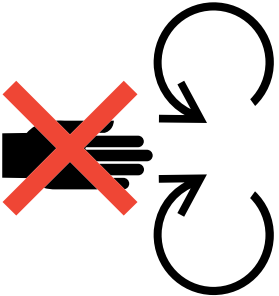





**Table 1. Safety Decals**

Part Number	Description
20813	<div style="border: 1px solid black; padding: 10px;"> <div style="background-color: red; color: white; text-align: center; padding: 5px;">  <b>DANGER</b> </div> <div style="display: flex; justify-content: space-around; align-items: center; margin-top: 10px;">   </div> <div style="text-align: center; margin-top: 10px;"> <p><b>ROTATING FLIGHTING HAZARD</b></p> <p>To prevent death or serious injury:</p> <ul style="list-style-type: none"> <li>KEEP AWAY from rotating auger flighting.</li> <li>DO NOT remove or modify auger flighting guards, doors, or covers. Keep in good working order. Have replaced if damaged.</li> <li>DO NOT operate the auger without all guards, doors, and covers in place.</li> <li>NEVER touch the auger flighting. Use a stick or other tool to remove an obstruction or clean out.</li> <li>Shut off and lock out power to adjust, service, or clean.</li> </ul> </div> </div>
20803	<div style="border: 1px solid black; padding: 10px;"> <div style="background-color: orange; color: black; text-align: center; padding: 5px;">  <b>WARNING</b> </div> <div style="display: flex; justify-content: space-between; align-items: center; margin-top: 10px;"> <div style="text-align: center;">   </div> <div style="margin-left: 20px;"> <p><b>MISSING GUARD HAZARD</b></p> <p>To prevent serious injury or death, shut off power and reattach guard before operating machine.</p> </div> </div> </div>



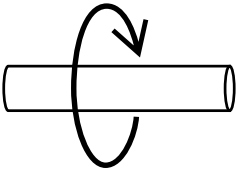



**Table 1 Safety Decals (continued)**

Part Number	Description
20804	<div style="border: 1px solid black; padding: 10px;"> <div style="background-color: #f4a460; text-align: center; padding: 5px;">  <b>WARNING</b> </div> <div style="display: flex; justify-content: space-around; align-items: center; margin-top: 10px;">   </div> <div style="text-align: center; margin-top: 10px;"> <p><b>ENTANGLEMENT HAZARD</b></p> <p>To prevent serious injury or death:</p> <ul style="list-style-type: none"> <li>• Keep body, hair, and clothing away from rotating pulleys, belts, chains, and sprockets.</li> <li>• Do not operate with any guard removed or modified. Keep guards in good working order.</li> <li>• Shut off and remove key or lock out power source before inspecting or servicing machine.</li> </ul> </div> </div>
20805	<div style="border: 1px solid black; padding: 10px;"> <div style="background-color: #f4a460; text-align: center; padding: 5px;">  <b>WARNING</b> </div> <div style="display: flex; justify-content: space-around; align-items: center; margin-top: 10px;">   </div> <div style="text-align: center; margin-top: 10px;"> <p><b>HIGH PRESSURE FLUID HAZARD</b></p> <p>Hydraulic fluid can cause serious injury if it penetrates the skin. If it does, see a doctor immediately.</p> <ul style="list-style-type: none"> <li>• Relieve system pressure before repairing, adjusting or disconnecting.</li> <li>• Wear proper hand and eye protection when searching for leaks. Use wood or cardboard instead of hands.</li> </ul> </div> </div>


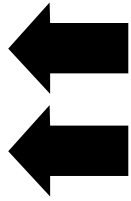
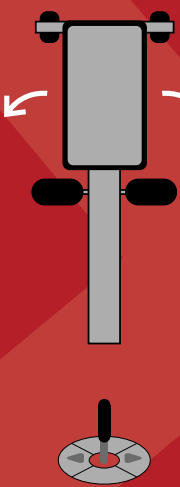
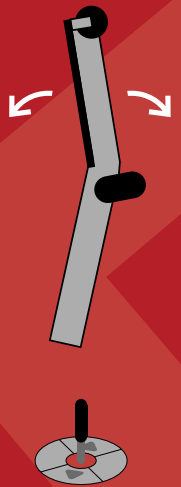
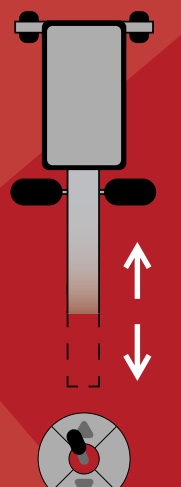


**Table 1 Safety Decals (continued)**

Part Number	Description
22950	<div style="border: 2px solid black; padding: 10px;"> <div style="background-color: #f4a460; padding: 5px; text-align: center;">  <span style="font-size: 24pt; font-weight: bold; color: black;">WARNING</span> </div> <div style="display: flex; justify-content: space-between; padding: 10px 0;"> <div style="width: 45%; text-align: center;">  </div> <div style="width: 50%; padding-left: 20px;"> <p>Moving Parts will cause severe injury.  KEEP AWAY</p> </div> </div> <div style="display: flex; justify-content: space-between; padding: 10px 0;"> <div style="width: 30%; text-align: center;">  </div> <div style="width: 65%; padding-left: 20px;"> <p>ROTATING SHAFT  Keep hair and loose clothing away</p> </div> </div> </div>
22957	<div style="border: 2px solid black; padding: 10px;"> <div style="background-color: #ffff00; padding: 5px; text-align: center;">  <span style="font-size: 24pt; font-weight: bold; color: black;">CAUTION</span> </div> <div style="padding: 10px;"> <ol style="list-style-type: none"> <li>1. SHUT OFF PTO when retracting or extending swing to or from its fully retracted position.</li> <li>2. Engaging spline shaft with PTO running will damage the machine.</li> <li>3. Make certain everyone is clear of the equipment before applying power or moving the machine.</li> </ol> </div> </div>



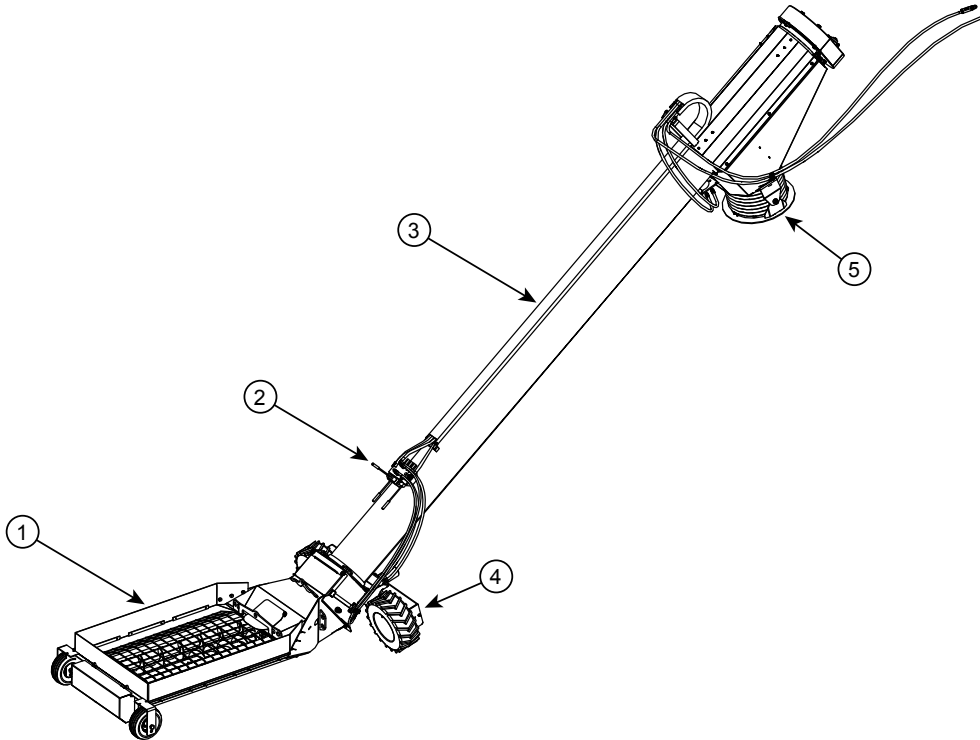
**Table 1 Safety Decals (continued)**

Part Number	Description
22948	<div style="border: 1px solid black; padding: 10px;"> <div style="background-color: #0056b3; color: white; text-align: center; padding: 5px;"><b>NOTICE</b></div> <div style="display: flex; justify-content: space-between; padding: 10px 0;"> <div style="width: 60%;"> <p>DO NOT operate the PTO when retracted past this point.</p> <p>Failure to follow could result in equipment damage.</p> </div> <div style="width: 30%; text-align: center;">  </div> </div> </div>
22949	<div style="border: 1px solid black; padding: 10px;"> <div style="background-color: #0056b3; color: white; text-align: center; padding: 5px;"><b>NOTICE</b></div> <div style="display: flex; justify-content: space-between; padding: 10px 0;"> <div style="width: 20%; text-align: center;">  </div> <div style="width: 75%;"> <p>DO NOT operate the PTO when retracted past this point.</p> <p>Failure to follow could result in equipment damage.</p> </div> </div> </div>
22952	<div style="border: 1px solid black; padding: 10px; background-color: #e67e22; border-radius: 15px;"> <div style="display: flex; justify-content: space-around; align-items: center; text-align: center;"> <div style="width: 30%;">  <p><b>SWING</b></p> </div> <div style="width: 30%;">  <p><b>TIP-UP</b></p> </div> <div style="width: 30%;">  <p><b>XTEND</b></p> </div> </div> <p style="font-size: small; margin-top: 10px;">Patents: CA 2,683,843; US 7,946,416; Other Patents Pending</p> </div>

# 3. Features

Below are some of the main features of the Westfield MKX-Tend Hopper.

**Figure 3. Typical MKX-Tend Hopper Components**



**Table 2. Typical MKX-Tend Hopper Components**

Item	Description	Item	Description
1	Hopper	4	Wheel Drive Assembly
2	Positioning Controls	5	Swing Ring
3	Swing Auger		

## General Description

The MKX-Tend hopper swing auger is an option for the Westfield MKX130. It provides the ability to drive hopper bottom trailers into place with the MKX-Tend hopper retracted and when extended will reach both trailer hopper gates on most straight trailers without having to re-position the truck. The MKX-Tend hopper may be extended under the trailer under operator control safely and with ease once the trailer is stopped.



# 4. Assembly



Before continuing, ensure you have completely read and understood this manual's Safety section, in addition to the safety information in the section(s) below.

## 4.1. Assembly Safety

---

### WARNING

- Do not take chances with safety. The components can be large, heavy, and hard to handle. Always use the proper tools, rated lifting equipment, and lifting points for the job.
- Carry out assembly in a large open area with a level surface.
- Always have two or more people assembling the MKX-Tend hopper.
- Make sure you have sufficient lighting for the work area.
- Tighten all fasteners according to their specifications. Do not replace or substitute bolts, nuts, or other hardware that is of lesser quality than the hardware supplied by the manufacturer.

## 4.2. General Assembly

---

The MKX-Tend hopper is available installed as part of the normal assembly of an MKX130 auger or as a kit to replace an already-installed low-profile hopper.

Refer to the appropriate assembly manual for general assembly information, including auger assembly sequence and the standard list of tools required (installation of the MKX-Tend hopper replaces the installation of the Low Profile hopper, swing tube and spout head in the auger assembly sequence).

### General Installation

1. Secure an appropriate lifting device with lifting straps or chains to the MKX-Tend hopper.
2. Check that the u-joint spline and splined shaft on the lower gearbox are clean, then apply a light film of grease on this splined shaft.
3. Remove the collector service door/cover on side of collector.
4. Lower the MKX-Tend hopper collector onto the boot while guiding the u-joint onto the gearbox shaft. Reach through the collector service door to rotate u-joint (as necessary), to line up with the splined gearbox shaft. Once positioned, the swivel ring should be resting flat on the boot surface.
5. Secure the ring in place using four retainer tabs, four retaining spacers and eight 3/8" x 3/4" bolts.
6. Lubricate the u-joint.
7. Close and secure the collector service door/cover.

**Figure 4. MKX-Tend Hopper General Installation****Installation for Retrofits**

1. Swing your old swing auger into a position out from the side of your auger that is safe to lift.
2. Secure an appropriate lifting device with lifting straps or chains to your old swing.
3. Apply slight tension to prevent swing from falling when the fasteners are removed.
4. Remove the bolts and washers that hold swivel ring of your old swing unit down to the auger boot. Keep the parts for use on your new MKX-Tend hopper.
5. Usually the lower half of the U-Joint that connects the swing auger to main auger is splined and should slip up as the swing auger is lifted. If the spline is seized (usually due to running fertilizer through the auger) then it may have to be pried off, and sometimes heating is necessary. Lift the old swing auger off the main auger boot in a safe manner.
6. The MKX-Tend hopper swing can be lowered into place on the main auger using the same lift system that you lifted the old one off. Grease the lower spline before lowering the auger. Remove the service door/cover on side of collector. Align u-joint by reaching down through this hole. Lower the MKX-Tend hopper auger into place.
7. Secure the ring in place using the existing bolts, retaining spacers and retainer tabs.

**4.3. Verify Auger Assembly**

During the assembly of the auger, the following standard parts must be replaced by parts modified to be compatible with the MKX-Tend Hopper:

- intake-side single cross brace
- lift arm (installed with hydraulic winch)

**4.3.1 Install the MKX-Tend Hopper Lift Arm**

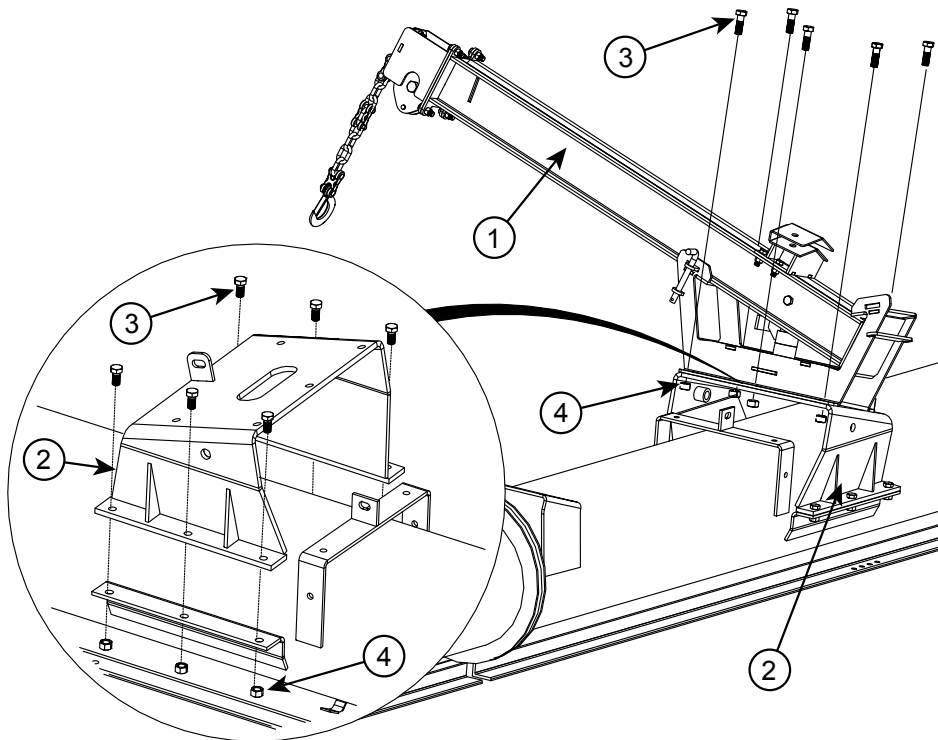
During the assembly of the auger, ensure that the standard lift arm is replaced by the lift arm listed in [Table 3](#) below.

1. Attach the lift arm mount to the lift arm mount brackets using six 1/2" x 1-1/2" bolts and locknuts.
2. Position the hopper lift arm assembly on the MKX-Tend hopper lift arm mount bracket with the arm overhanging the side of the auger that the hopper will be operating on.
3. Fasten the hopper lift arm assembly to the mount bracket using five 1/2" x 1-1/2" bolts and locknuts.

**Table 3. Replacement Lift Arm**

Standard Lift Arm	MKX-Tend Hopper Lift Arm (Replacement)
10-20030	10-22982

**Figure 5. MKX-Tend Hopper Lift Arm**



**Table 4. Lift Arm Components**

Item	Description	Part Number
1	Hopper Lift Arm Assembly	10-22982
2	MKX130 Lift Arm Mount	10-21769
3	Bolt, 1/2" x 1-1/2"	10-19589
4	Locknut, 1/2"	10-19599

### 4.3.2 Replace the Short Truss Brace

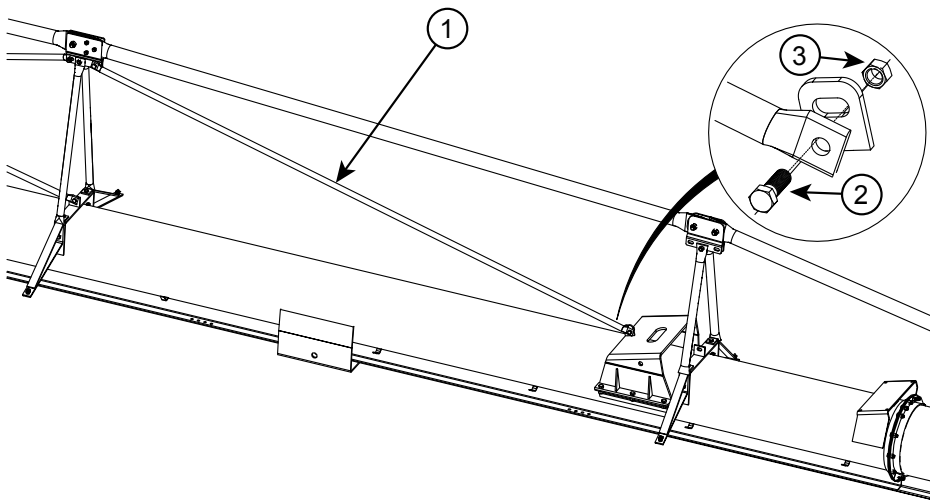
During the assembly of the auger, ensure that the standard single truss brace tube closest to the boot is replaced by the short truss brace tube listed in [Table 5](#) below.

1. Position the new short truss brace tube between the truss tower and lift arm mount, and secure it with a 1/2" x 1-1/2" bolt and locknut at each end.

**Table 5. Replacement Truss Brace Tube**

Model	Standard Truss Brace Tube	Short Truss Brace Tube (Replacement)
130-84	10-20078	10-21489
130-94		
130-114	10-20254	

**Figure 6. MKX130 Short Truss Brace Tube**



**Table 6. Short Truss Brace Components**

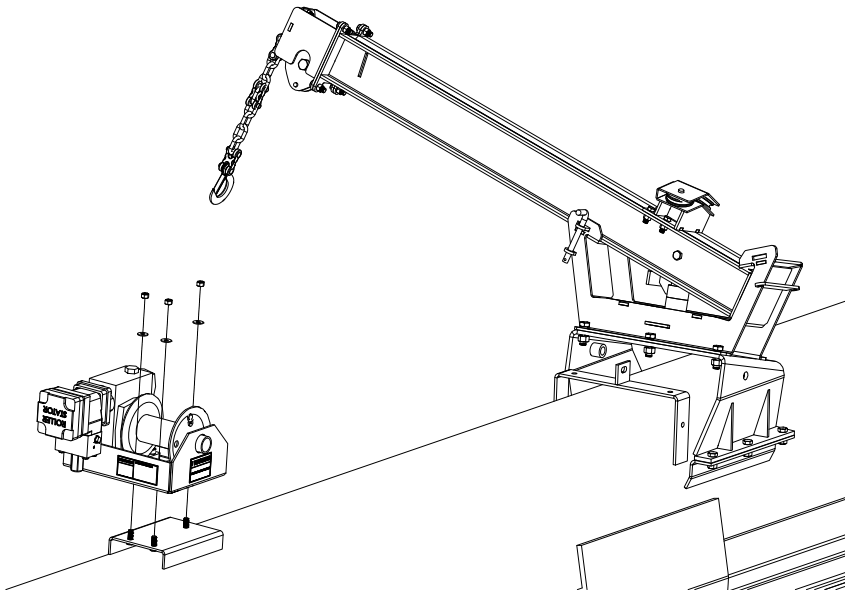
Item	Description	Part Number
1	MKX130 Short Truss Brace Tube	10-21489
2	Bolt, 1/2" x 1-1/2"	10-19589
3	Locknut, 1/2"	10-19599

### 4.3.3 Install the Hydraulic Winch

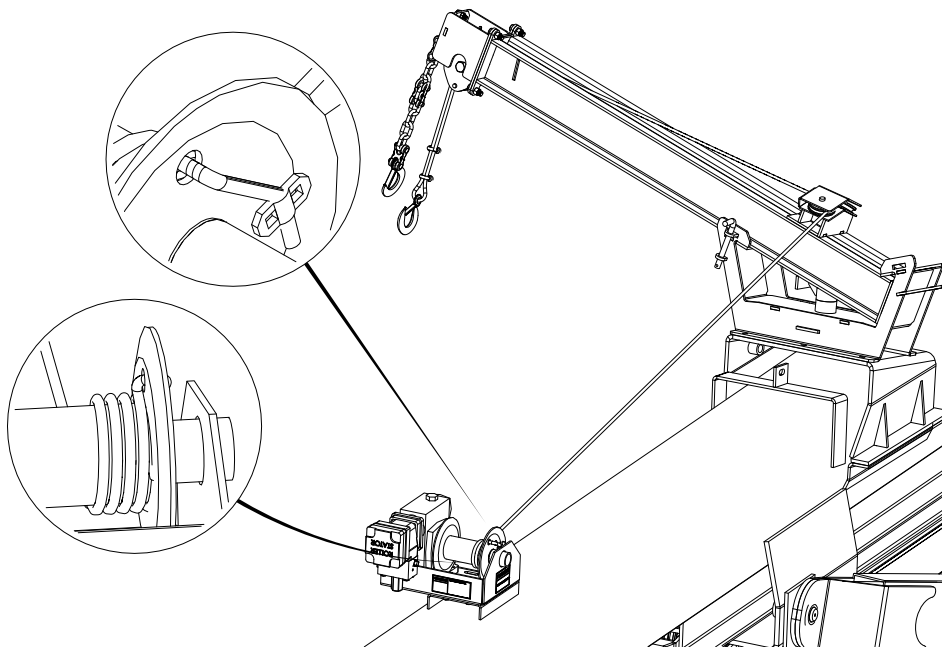
1. Position the hydraulic winch on the winch mounting plate, and secure it using three 3/8" washers and three 3/8" locknuts as shown in [Figure 7 on page 24](#).
2. Thread the winch cable through the two lift arm pulleys (at the top of the lift arm and at the pulley guide), then under the spool and connect it to the spool (minimum 3 wraps around the spool, feed cable through hole in side of spool, and secure with clamp and clamp hardware) as shown in [Figure 8 on page 24](#).
3. Connect the hydraulic hoses to the winch, and install pioneer couplings on the hose ends.
4. Thread both hoses through hydraulic hose upper catches on side of auger lower tube and boot. Tighten hydraulic hose upper catches slightly to hold hoses in place.



**Figure 7. Installing the Hydraulic Winch**

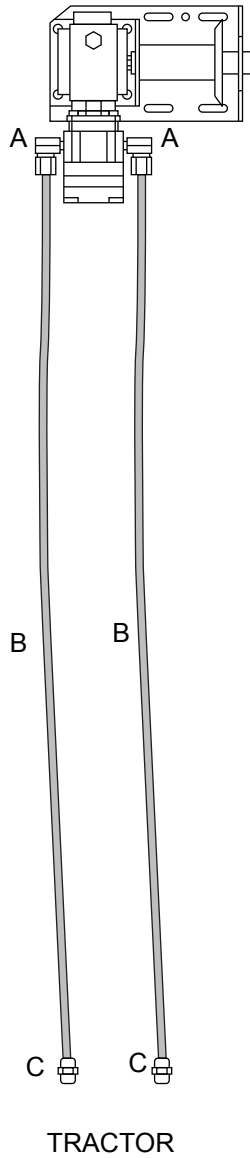


**Figure 8. Installing the Winch Cable**





**Figure 9. Installing the Hydraulic Winch Hose**



**Table 7. Hydraulic Winch Hose Components**

Part	Description
A	Steel Elbow, 1/2 MNPT x 1/2 FNPSM (28478)
B	3/8" x 215" Hydraulic Hose (22611)
C	Pioneer Coupler (9900047)



# 5. Operation



Before continuing, ensure you have completely read and understood this manual's Safety section, in addition to the safety information in the section(s) below.



This manual is a supplement to the MKX130 Series Operator Manual. Please ensure that you have read and understood that manual.

## 5.1. Operation Safety

---



### WARNING

- Keep away from rotating and moving parts, including the auger flighting, drive components, shafts, and bearings.
- Always operate with guards, covers, and shields in place.
- Have another trained person nearby who can shut down the equipment in case of accident.
- Keep the work area clear of bystanders.
- Keep the work area clean and free of debris.
- Ensure maintenance has been performed and is up to date.

## 5.2. Transport Preparation

---

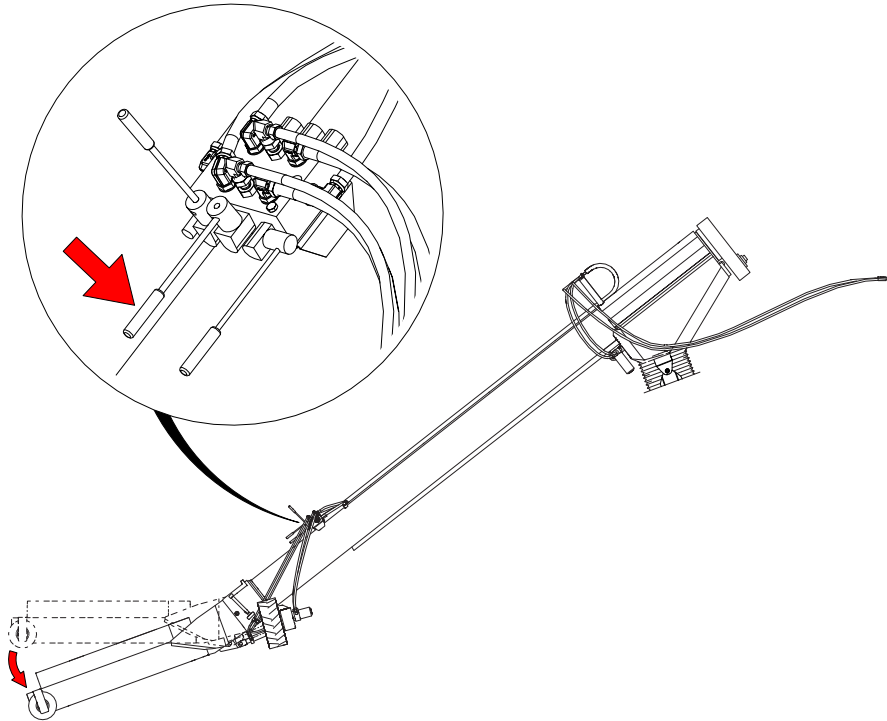
Position the MKX-Tend hopper in the transport configuration following the MKX130 Operator Manual instructions and the following:

1. Fully extend the MKX-Tend hopper to reach the lift arm on the main auger.
2. Make the hopper as flat as possible to avoid interference with the frame before lifting the swing into transport, as shown in [Figure 10 on page 27](#).
3. Attach the winch cable to the hopper, lift into position, and secure the transport chain, as shown in [Figure 12 on page 28](#).

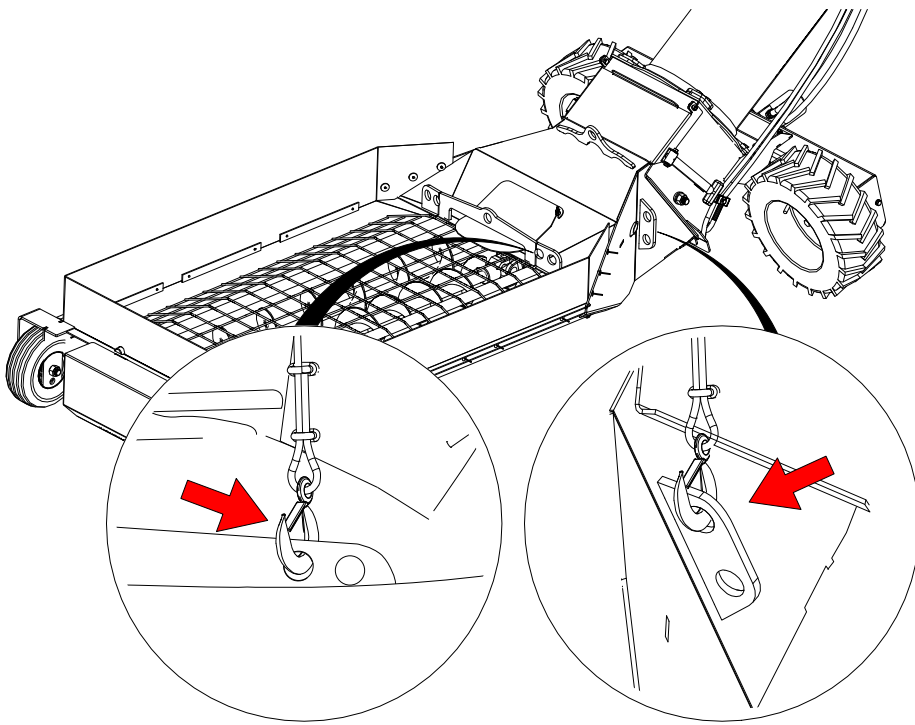
### Note

The MKX130–74 connects to the hopper in a different position than the other models.

**Figure 10. Flatten MKX-Tend Hopper**



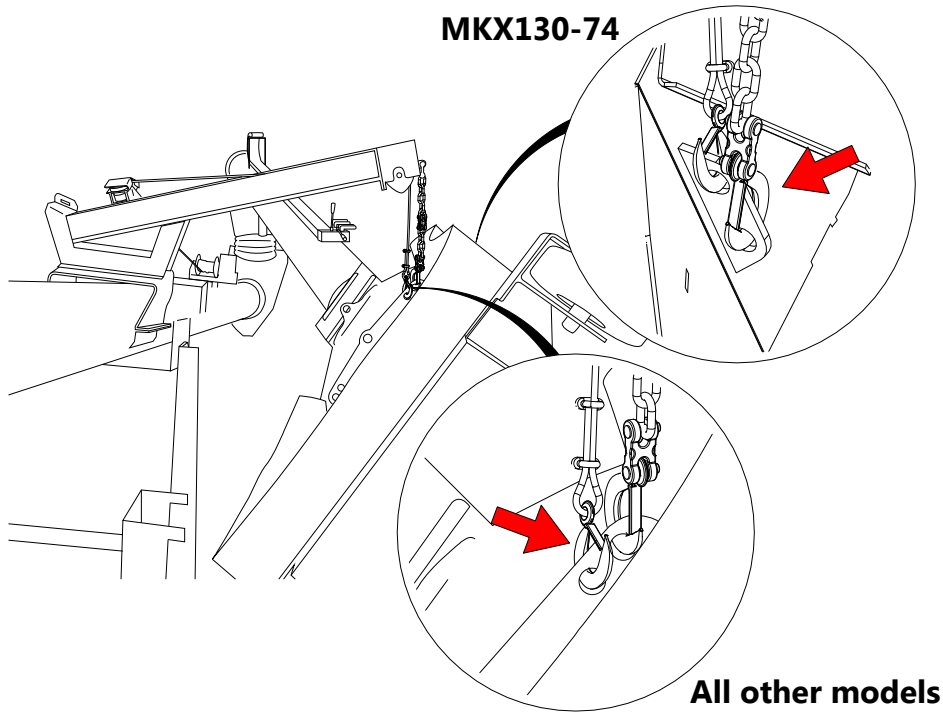
**Figure 11. Cable Attachment**



**All other models**

**MKX130-74**



**Figure 12. Transport Position and Chain Attach**

### 5.3. Operator Controls

---

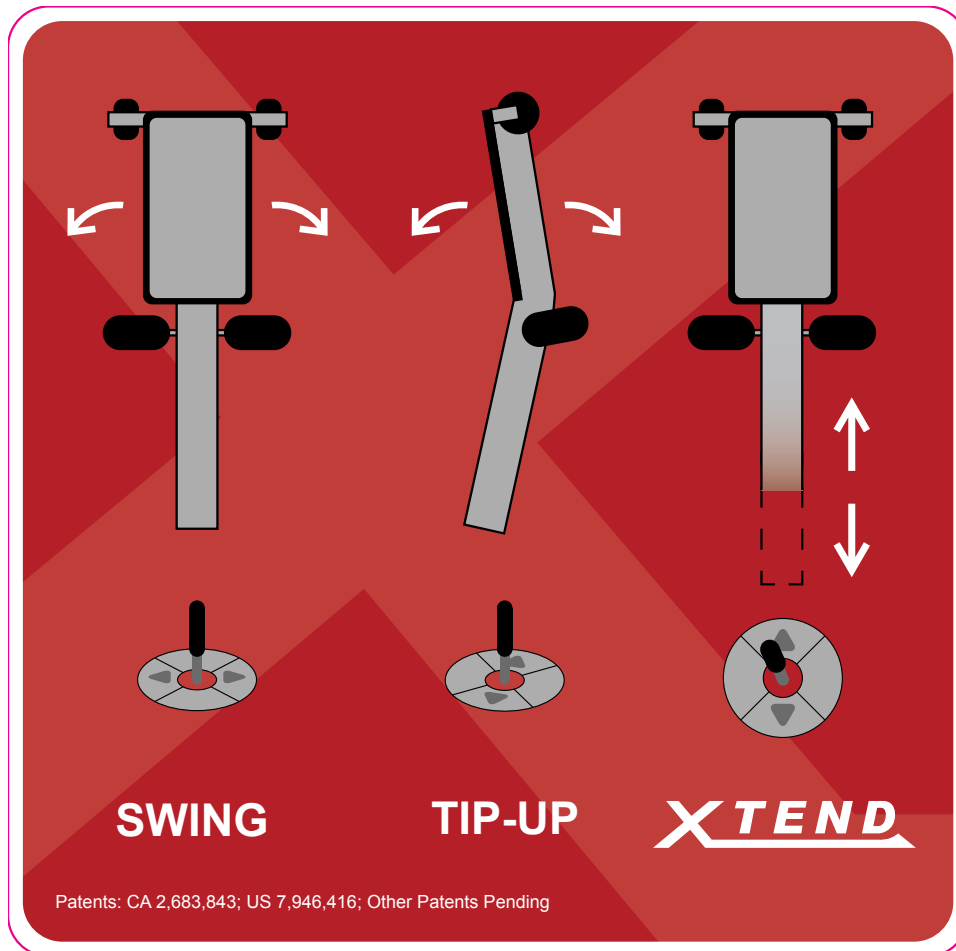
Refer to [Figure 13 on page 29](#) for the operator controls.

The MKX-Tend Hopper auger adds two functions to a normal swing auger:

1. The ability to extend and retract the hopper.
2. The ability to tilt the end of the hopper up or down.

All controls for these functions are located on the swing tube where the operator has easy access to the handles on the trailer for opening the chute gates. The functions are identified on the operating label shown below.

Figure 13. MKX-Tend Hopper Operator Controls



## 5.4. Start-Up and Break-In

Your MKX-Tend hopper does not require an elaborate break in. However, following a few simple tips during the initial operation can add to the reliability and life of your machine.

If any unusual noises or vibrations are encountered, determine the source, shut the auger off, lock out the power source and adjust. If unsure of the problem or procedure, contact your local Westfield dealer.

1. Start the tractor and run at low idle.
2. Engage the tractor PTO and slowly increase to operating speed. Operate at 3/4 capacity for the first few truckloads to break in the new components.
3. Place the tractor hydraulic control lever in detent.

### Important

When starting the MKX-Tend hopper for the first time, be prepared for an emergency shut down in case of excessive vibration or noise.

### 5.4.1 Prior to First Use

1. Re-torque all other fasteners and hardware, if required.

2. Check that all safety decals are installed and legible. Apply new decals if required.
3. Check that no hoses are pinch or being crimped. Re-align as required.
4. Check that all guards are installed and working as intended.
5. Check drive chain tension and alignment. Adjust as required.
  - Hopper drive chain — See [Section 6.4. – Adjusting the Hopper Drive Chain Tension on page 35](#)
  - Wheel drive chain — See [Section 6.5. – Adjusting the Wheel Drive Chain Tension on page 37](#)
  - Swing auger chain — See [Section 6.6. – Swing Auger Chain Tension on page 38](#)
6. Lubricate all grease fittings and oil chains. See [Section 6.2. – Lubricate the Equipment on page 32](#)
  - Hopper/transition u-joints
  - Hopper bearings
  - Auger chain drive bearings
  - Swing ring u-joint
7. Check hopper winch and lift cable for damage (fraying, kinking and unraveling). Replace as required.

### 5.4.2 After First Use

1. Check that no hoses are pinched or being crimped. Look for any signs of leaking hydraulic fluid.
2. Check drive chain tension and alignment.
  - Hopper drive chain — See [Section 6.4. – Adjusting the Hopper Drive Chain Tension on page 35](#)
  - Wheel drive chain — See [Section 6.5. – Adjusting the Wheel Drive Chain Tension on page 37](#)
  - Swing auger chain — See [Section 6.6. – Swing Auger Chain Tension on page 38](#)
3. Check hopper winch and lift cable for damage (fraying, kinking and unraveling).
4. Go to the normal servicing and maintenance schedule as defined in the Maintenance section.

## 5.5. MKX-Tend Hopper Operation

---

1. Lower the MKX-Tend hopper swing from the transport position, tilt the end of the hopper up so that the weight is on the powerswing tires and place it in the unloading position, roughly perpendicular to the auger.

#### Note

In regular configurations, it should not be possible to contact the tractor cab by retracting the MKX-Tend hopper, however use caution as this can happen when using a right angle PTO drive to operate your auger.

2. Lower the hopper fully to shift the weight from the powerswing tires onto the hopper tires.
3. Retract the MKX-Tend hopper all the way.
4. Position the grain truck roughly two feet from the end of the MKX-Tend hopper, with the MKX-Tend hopper centered between the truck hoppers.
5. Extend the MKX-Tend hopper fully.
6. Tilt/raise the MKX-Tend hopper up to shift the weight onto the powerswing tires and position it under the desired truck hopper.
7. Lower/tilt the MKX-Tend hopper to be flush with the ground when unloading.

8. Engage the tractor PTO, unload the grain truck until flow stops and close the truck hopper.
9. Repeat the procedure to unload the remaining truck hoppers.
10. Disengage the PTO drive.
11. Retract the hopper fully to move the grain truck out of the way.

**Note**

The MKX-Tend hopper position may be moved between truck hoppers with the PTO running as long as the spline shaft at the top does not become disengaged. On the 13" MKX-Tend hopper there is 24" of free movement back from full extension. The end of free working travel is indicated by the MKX-Tend hopper Decal starting to appear from under the collector cover.

**NOTICE**

The spline can become damaged if they disengage while the PTO is operating.

Keep movement limited between the two truck hoppers.

# 6. Maintenance



Before continuing, ensure you have completely read and understood this manual's Safety section, in addition to the safety information in the section(s) below.



This manual is a supplement to the MKX130 Series Operator Manual. Please ensure that you have read and understood that manual.

## 6.1. Maintenance Safety

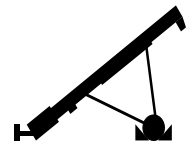
### WARNING

- Keep components in good condition. Follow the maintenance procedures.
- Ensure the service area is clean, dry, and has sufficient lighting.
- Do not modify any components without written authorization from the manufacturer. Modification can be dangerous and result in serious injuries.
- Shut down and lock out power before maintaining equipment.
- After maintenance is complete, replace all guards, service doors, and/or covers.
- Use only genuine Westfield replacement parts or equivalent. Use of unauthorized parts will void warranty. If in doubt, contact Westfield or your local dealer.



#### Before attempting maintenance of any kind:

- Lower the MKX-Tend hopper fully.
- Chock wheels.
- Support tube if performing maintenance on the undercarriage assembly.
- **If equipped with hydraulics:** Before applying pressure to a hydraulic system, make sure all components are tight and that hoses and couplings are in good condition.



## 6.2. Lubricate the Equipment

Your equipment can operate at top efficiency only if clean fluids and lubricants are used. Use clean containers to handle all fluids and lubricants. Store them in an area protected from dust, moisture, and other contaminants.

1. Wipe the grease fittings with a clean cloth before greasing to avoid injecting dirt and grit.
2. Use a hand-held grease gun for all greasing.
3. If fittings will not take grease, remove and clean thoroughly.
4. Replace fittings if they are broken or will not accept grease.



Use SAE multi-purpose high-temperature grease with extreme pressure (EP) performance. SAE multi-purpose lithium-based grease is also acceptable.

## 6.3. Service Interval

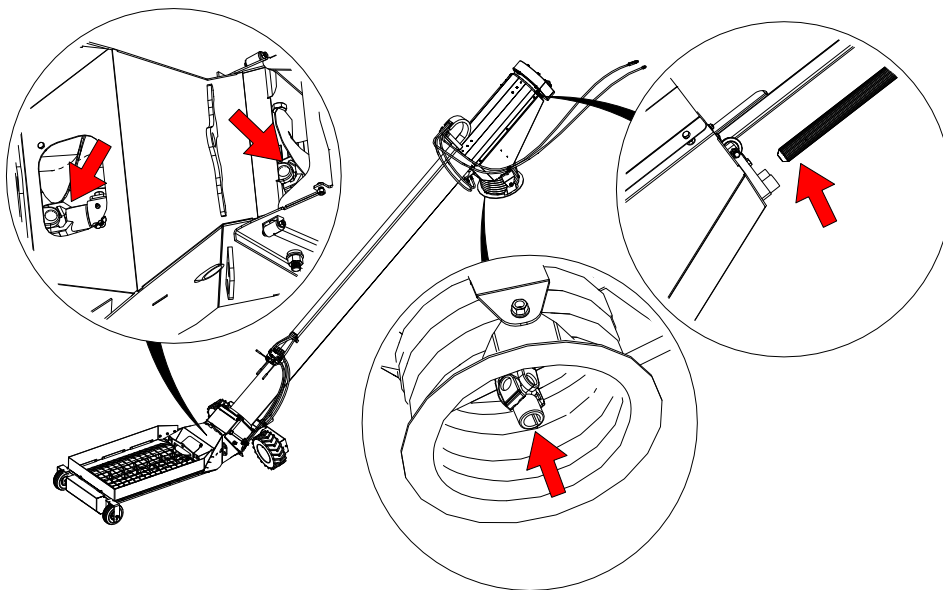
### 6.3.1 Weekly Service

Complete the following maintenance weekly when using the MKX-Tend hopper.

#### Grease and Lubrication

- Grease the hopper u-joints — (2 locations)
- Grease the collector swivel ring u-joint — (1 location)
- Lubricate the drive spline — Lightly coat the spline shaft with grease or spray lube

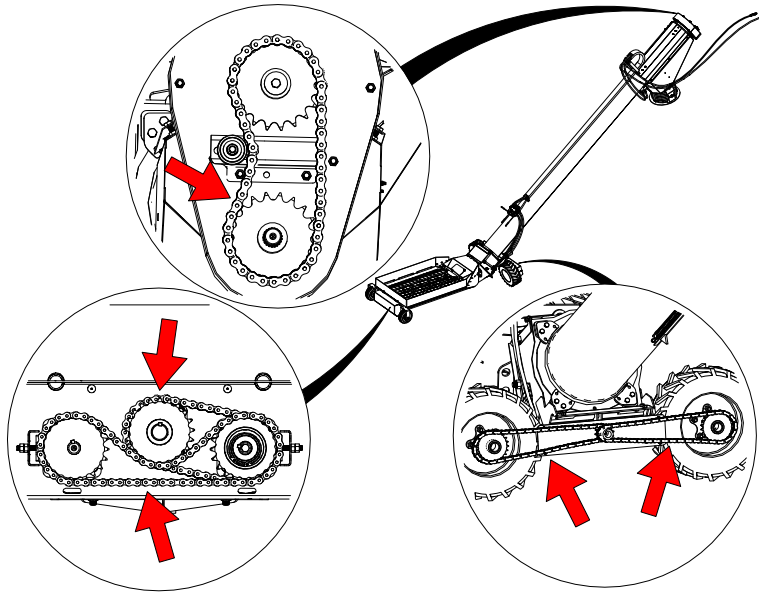
**Figure 14. MKX-Tend Hopper Grease and Lubrication Points**



#### Check Chain Tension

- Check hopper drive chain tension — See [Section 6.4. – Adjusting the Hopper Drive Chain Tension on page 35](#)
- Check wheel drive chain tension — See [Section 6.5. – Adjusting the Wheel Drive Chain Tension on page 37](#)
- Check swing auger drive chain tension — See [Section 6.6. – Swing Auger Chain Tension on page 38](#)

**Figure 15. MKX-Tend Hopper Chain Tension Check Points**

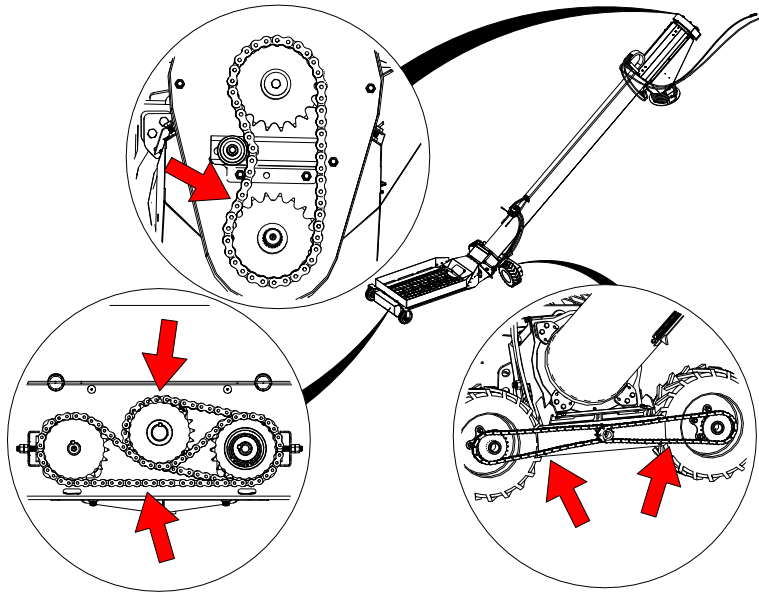


### 6.3.2 Semi-Annual Service

#### Lubrication Points

- Oil hopper drive chain with a light coat of oil.
- Oil wheel drive chain with a light coat of oil.
- Oil the auger chain drive with a light coat of oil.

**Figure 16. MKX-Tend Hopper Lubrication Points**

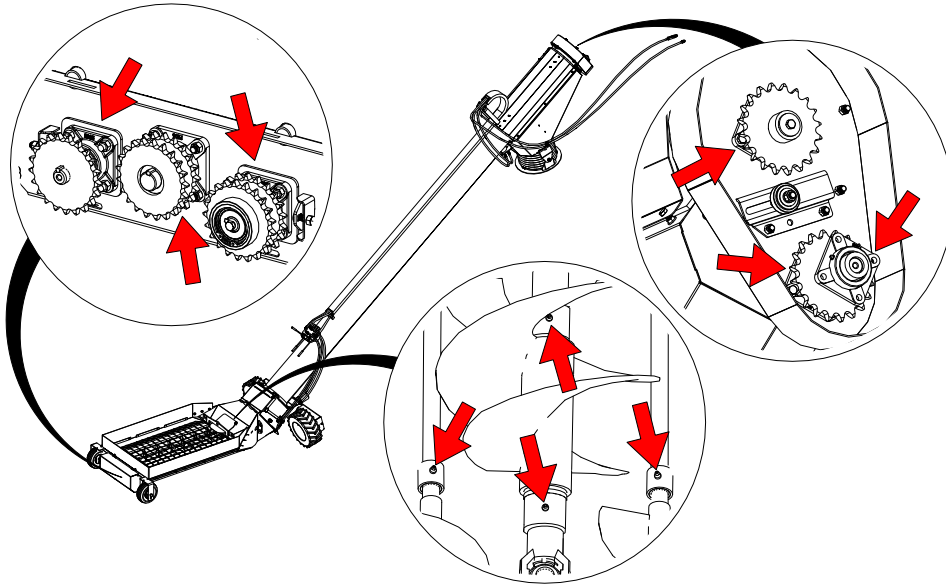


### 6.3.3 Annual Service

#### Grease Points

- Grease hopper bearings (1 shot) — (3 locations)
- Grease the hopper flight support bushings — (2 locations)
- Grease the transition flight support bushings — (2 locations)
- Grease auger chain drive bearings (1 shot) — (3 locations)

**Figure 17. MKX-Tend Hopper Grease Points**

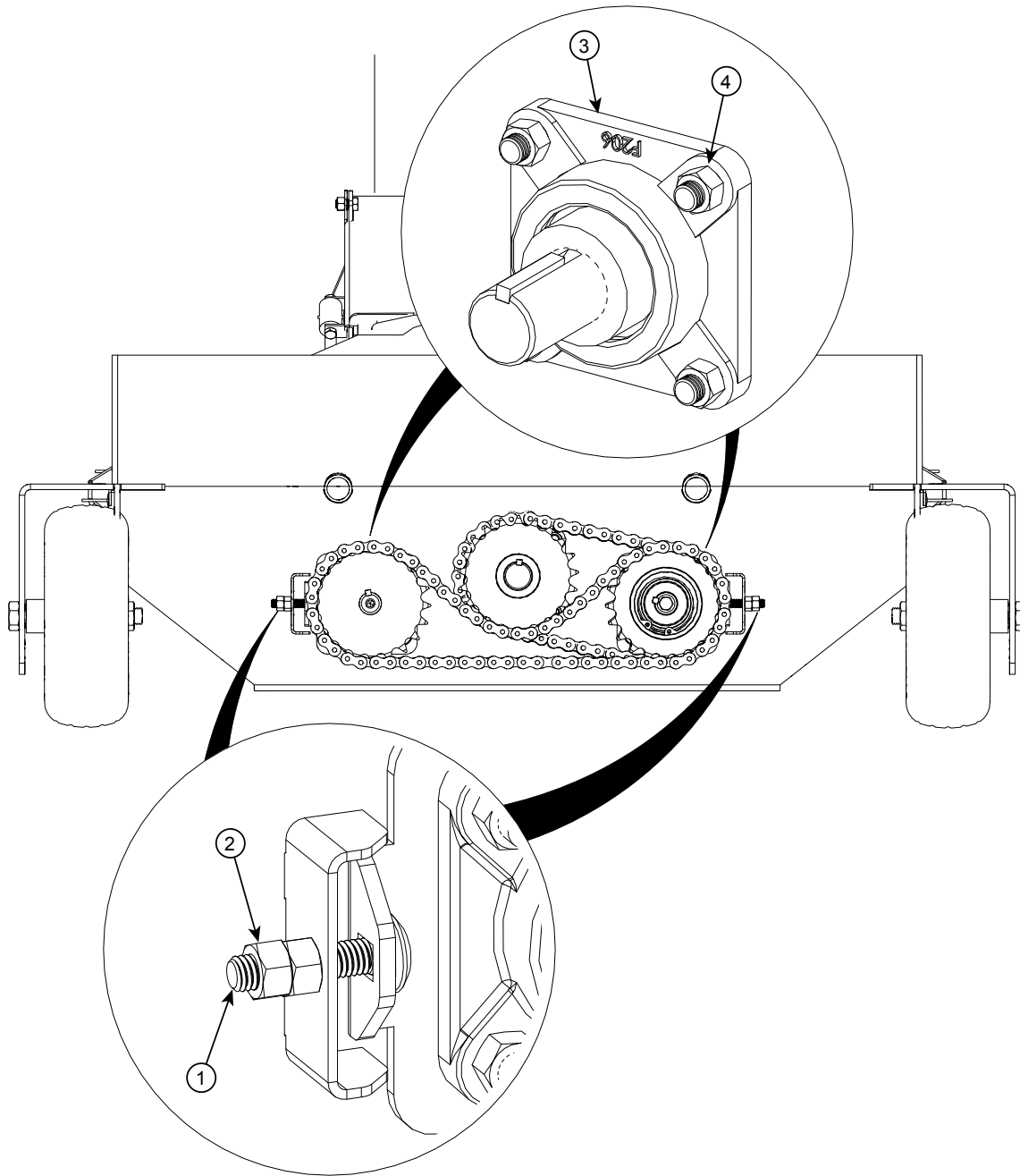


## 6.4. Adjusting the Hopper Drive Chain Tension

Adjust the hopper drive chain tension following the procedure below.

1. Remove the hopper chain guard.
2. Inspect the sprockets and chains for wear or misalignment.
3. Loosen the bearing nuts for the sprocket that is to be tightened.
4. Loosen the chain tensioner bolt nuts and adjust bolt to take the slack out of the chain. Over-tightening will cause excessive wear.
5. Tighten the nuts on the adjust bolt to lock in place.
6. Tighten the bearing nuts and replace the guard.

**Figure 18. MKX-Tend Hopper Drive Chain Tension**



**Table 8. MKX-Tend Hopper Drive Components**

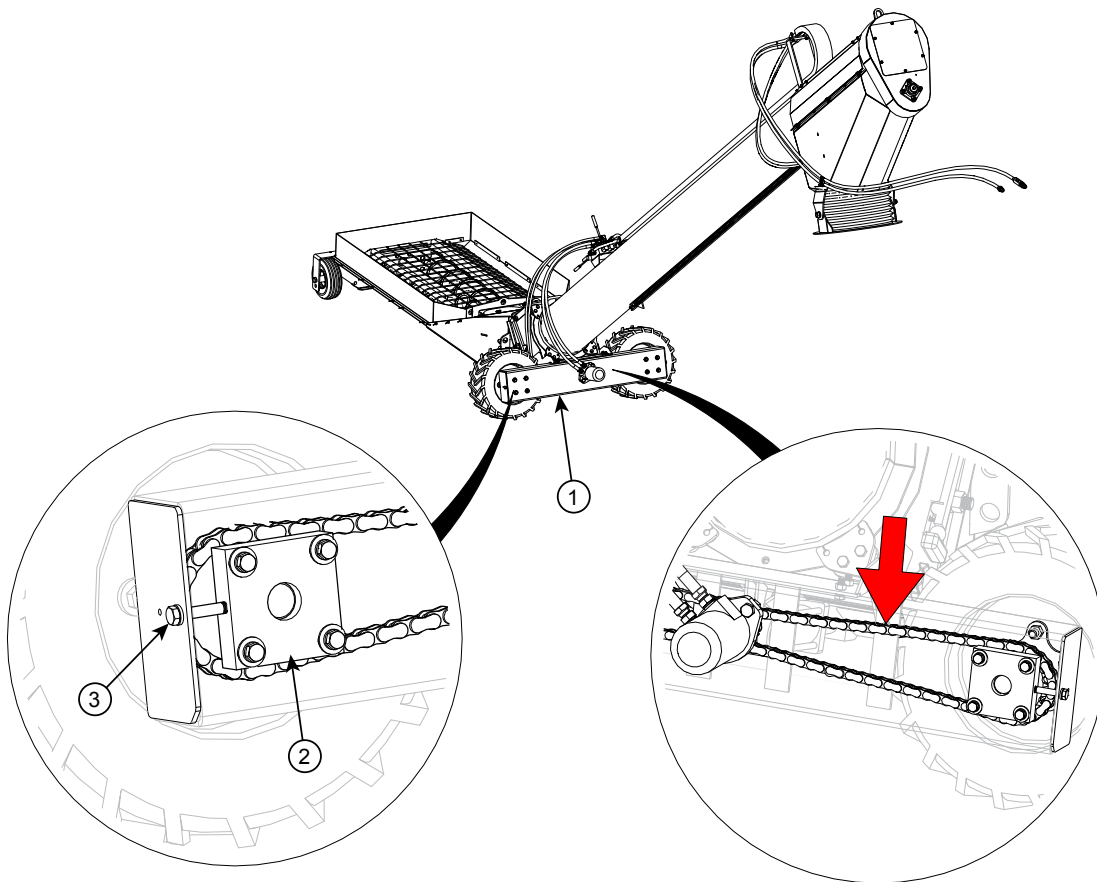
Item	Description	Item	Description
1	Tensioner Bolt	3	Bearing
2	Tensioner Bolt Nut	4	Bearing Nut

## 6.5. Adjusting the Wheel Drive Chain Tension

Adjust the wheel drive chain following the procedure below.

1. Remove the guard and check the chain tension. The chain should have approximately 1/2" slack in the middle.
2. To tighten the chain, loosen the four bolts on each wheel spindle and draw the wheel spindle away from the center using the draw bolt on each end of the housing. Do not completely remove the spindle bolts. Loosen the spindle to allow it to slide freely when adjusting the draw bolts.
3. Re-tighten the four bolts on each wheel spindle and replace the guard.

**Figure 19. Wheel Drive Chain Tension**



**Table 9. MKX-Tend Hopper Wheel Drive Components**

Item	Description
1	Power Swing Frame
2	Spindle
3	Draw Bolt

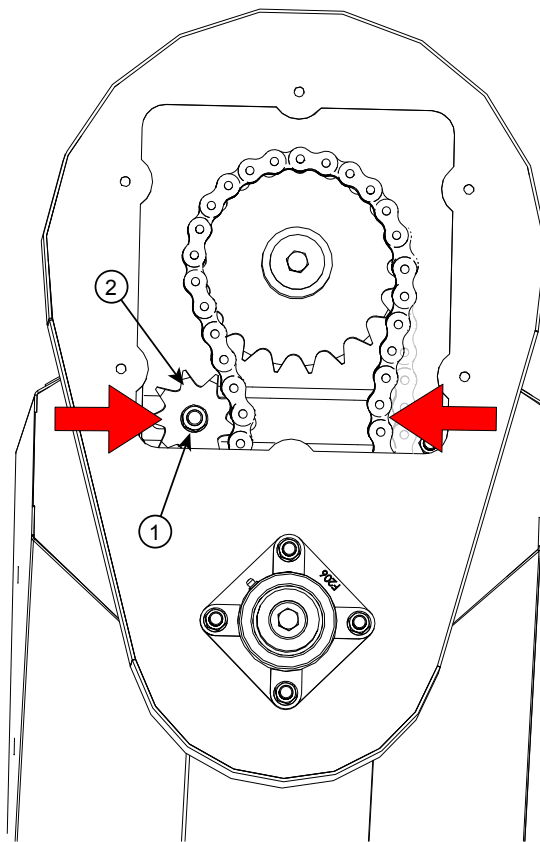


## 6.6. Swing Auger Chain Tension

Adjust the swing auger chain drive following the procedure below.

1. Remove the chain box access cover.
2. Loosen the nut on the end of the chain tensioner roller and move the idler sprocket toward the chain until the chain has approximately 1/2" slack in the middle.
3. Tighten the nut and replace the access cover.

**Figure 20. Swing Auger Chain Tension**



**Table 10. Swing Auger Components**

Item	Description
1	Chain Tensioner Roller Nut
2	Idler Sprocket

# 7. Troubleshooting



Before continuing, ensure you have completely read and understood this manual's Safety section, in addition to the safety information in the section(s) below.



This manual is a supplement to the MKX130 Series Operator Manual. Please ensure that you have read and understood that manual.



**WARNING** Shut down and lock out all power sources before diagnosing any of the causes or attempting any of the solutions below.

In the following section, we have listed some causes and solutions to some of the problems you may encounter.

If you encounter a problem that is difficult to solve, even after having read through this section, please contact your local dealer or distributor. Before you contact them, please have this operation manual and the serial number from your machine ready.

Problem	Cause	Solution
Low capacity	Tractor PTO rpm is set too slow	Adjust the tractor to 1000rpm if using a reducer gearbox and 540rpm if not using a reducer.
Sprocket that moves the retractor tube in and out is slipping on chain.	The retractor tube chain is not close enough to the sprocket.	Loosen the bolt that attaches the guide bearing. Adjust the tensioner bolt to push the guide bearing against the track to move the chain closer to the sprocket. Re-tighten the guide bearing bolt.
Hydraulic functions are too fast.	Hydraulic flow is set too high on tractor.	Lower the hydraulic flow on the tractor. Should be approximately 8 GPM.



# 8. Specifications

**Table 11. MKX-Tend Hopper Specifications**

<b>Specification</b>	<b>MKX-Tend 130</b>
Tractor Hydraulic Flow	Adjust to 8 GPM
Tractor PTO Speed	540/1000 rpm
Hopper Height	12"
Hopper Length	50"
Hopper Width	36"
Total Swing Weight	1500 lbs
Weight on Lift Arm	800 lbs
Power Swing Tire Pressure	20 psi
PTO Operating Range	24"



# 9. Appendix

## 9.1. Tightening O-Ring Fittings

1. Inspect o-ring and seat for dirt or obvious defects.
2. On the angle fittings, back the lock nut off until washer bottoms out at top of groove.
3. Hand-tighten fitting until backup washer or washer face (if straight fitting) bottoms on face and o-ring is seated.
4. Position angle fittings by unscrewing no more than one turn.
5. Tighten straight fittings to torque shown.
6. Tighten while holding body of fitting with a wrench.

**Table 12. O-Ring Fittings**

Tube Size OD (in)	Nut Size Across Flats (in)	Torque Values <sup>1</sup> (N·m)	Torque Values <sup>1</sup> (ft·lb)	# of Turns to Tighten (Flats)	Turn (After Finger Tightening)
3/8	1/2	8	6	2	1/3
7/16	9/16	12	9	2	1/3
1/2	5/8	16	12	2	1/3
9/16	11/16	24	18	2	1/3
3/4	7/8	46	34	2	1/3
7/8	1	62	46	1-1/2	1/4
1-1/16	1-1/4	102	75	1	1/6
1-3/16	1-3/8	122	90	1	1/6
1-5/16	1-1/2	142	105	3/4	1/8
1-5/8	1-7/8	190	140	3/4	1/8
7/8	2-1/8	217	160	1/2	1/12




<sup>1</sup>

## 9.2. Bolt Torque Values

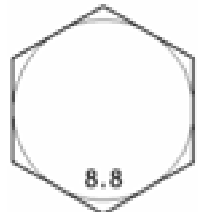

Table 13 and Table 14 give correct torque values for various bolts and capscrews. The bolt diameter is measured to the outside of the threads. When tightening all bolts, tighten the nut on the bolt to the torque specified in the tables, unless otherwise specified. Do not replace or substitute bolts, nuts, or other hardware that is of lesser strength than the hardware supplied by the manufacturer. Torque values indicated below are valid for non-greased or non-oiled threads and head, unless otherwise specified. Therefore, do not grease or oil bolts or capscrews unless otherwise specified in this manual. When using locking elements, increase torque values by 5%.



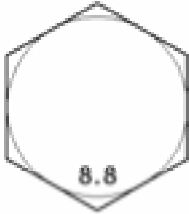

**Table 13. SAE Bolt Torque**

						
<b>Bolt Diameter</b>	<b>(N·m)</b>	<b>(ft·lb)</b>	<b>(N·m)</b>	<b>(ft·lb)</b>	<b>(N·m)</b>	<b>(ft·lb)</b>
1/4"	8	6	12	9	17	12
5/16"	13	10	25	19	36	27
3/8"	27	20	45	33	63	45
7/16"	41	30	72	53	100	75
1/2"	61	45	110	80	155	115
9/16"	95	60	155	115	220	165
5/8"	128	95	215	160	305	220
3/4"	225	165	390	290	540	400
7/8"	230	170	570	420	880	650
1"	345	225	850	630	1320	970

**Table 14. Metric Bolt Torque**

				
<b>Bolt Diameter</b>	<b>(N·m)</b>	<b>(ft·lb)</b>	<b>(N·m)</b>	<b>(ft·lb)</b>
M3	0.5	0.4	1.8	1.3
M4	3	2.2	4.5	3.3
M5	6	4	9	7
M6	10	7	15	11
M8	25	18	35	26
M10	50	37	70	52
M12	90	66	125	92
M14	140	103	200	148
M16	225	166	310	229
M20	435	321	610	450

**Table 14 Metric Bolt Torque (continued)**

				
M24	750	553	1050	774
M30	1495	1103	2100	1550
M36	2600	1917	3675	2710



# 10. Westfield Auger Warranty

Westfield Industries Ltd. warrants products of its manufacture against defects in materials or workmanship under normal and reasonable use for a period of one year after date of delivery to the original purchaser.

Our obligation under this warranty is limited to repairing, replacing, or refunding defective part or parts which shall be returned to a distributor or a dealer of our Company, or to our factory, with transportation charges prepaid. This warranty does not obligate Westfield Industries Ltd. to bear the cost of labor in replacing defective parts. Any defects must be reported to the Company before the end of the one year period.

This warranty shall not apply to equipment which has been altered, improperly assembled, improperly maintained, or improperly repaired so as to adversely affect its performance. Westfield Industries Ltd. makes no express warranty of any character with respect to parts not of its manufacture.

The foregoing is in lieu of all other warranties, expressed or implied, including any warranties that extend beyond the description of the product, and the IMPLIED WARRANTY of MERCHANTABILITY is expressly excluded.



**WESTFIELD** 

P.O. Box 39  
Rosenort, Manitoba, R0G 1W0 Canada  
Phone: (866) 467-7207 (Canada & USA) or (204) 746-2396  
Fax: (866) 768-4852

Website: [www.grinaugers.com](http://www.grinaugers.com)  
Email: [sales@grinaugers.com](mailto:sales@grinaugers.com)  
©Ag Growth International Inc. 2017  
Printed in Canada

**AGI** 